

PROPRIETARY RIGHTS ARE CLAIMED FOR THE MATERIAL DISCLOSED IN THIS DRAWING.

TYP. WALL THICKNESS = 2.0 TYP. RADIUS = 2.0

| LTR. | REVISIONS | DATE |
|------|-----------|----------|
| ✖ | ***** | 00-00-98 |

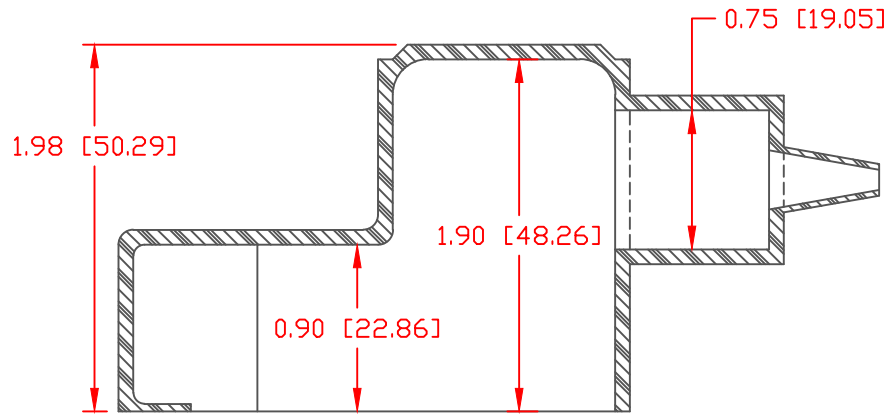

SECTION A-A

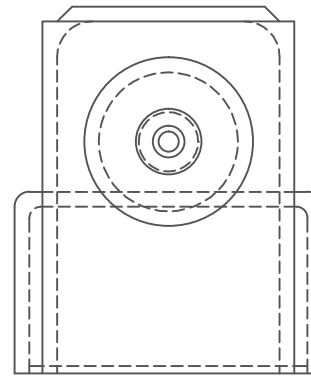

SEAL NO. 1 SHOWN

SEAL OPTIONS

SEAL THICKNESS = .8

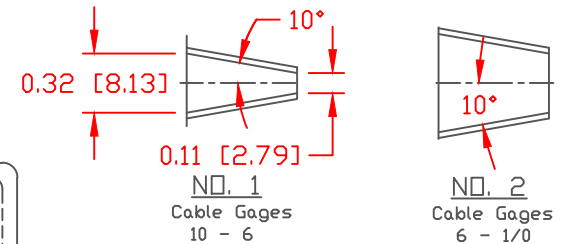

NO. 1
Cable Gages
10 - 6

NO. 2
Cable Gages
6 - 1/0

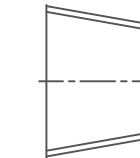

NO. 3
Cable Gages
1/0 - 4/0

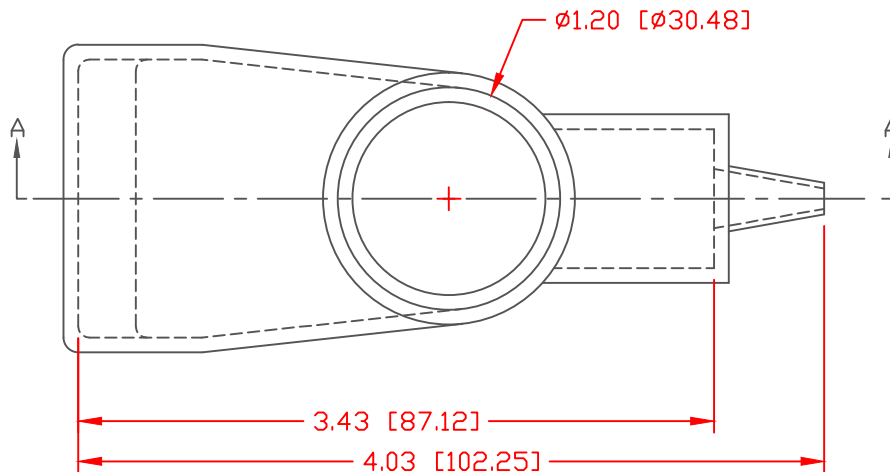

TOLERANCE UNLESS OTHERWISE SPECIFIED: ±.030"/±0.8mm
RADIAL DIAMETERS TO BE MEASURED OVER MANDRELS,
RING GAGES OR PIN GAGES OF SUITABLE SIZE

| | |
|-----------------------|---------------------------|
| VTE Material Part No: | 1101700102 |
| Material: | RED PVC |
| Material Part No | M1170 FR RD or Equivalent |
| Max. Operating Temp: | 105 C |
| Shore Durometer | "A" 15 SEC. 70+/-5 |
| Specific Gravity: | 1.34 |
| Ult. Elongation %: | 275 Minimum |
| Tensile Strength PSI: | 1600 PSI Minimum |
| U.L. Rating: | 94 V0 |

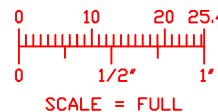

VTE Incorporated
 5437 Robinson Road, P.O. Box 790
 Pellston, Michigan 49769
 Telephone: 1-800-527-9256, 231-539-8000
 FAX: 231-539-0914

| | | | |
|-------------------------------------|----------------------|------------|-------------------------------|
| REF: | DATE: 3-31-98 | DRN BY: JC | WEIGHT: 071 LBS. / 31.9 G. |
| TITLE: MARINE ADAPTER WING NUT BOOT | | | |
| MATERIAL: | PART NO. 457N1F02 | | |
| COLOR: | DRG CLASS | | |