

PROPRIETARY RIGHTS ARE CLAIMED FOR THE MATERIAL DISCLOSED IN THIS DRAWING.

TYP. WALL THICKNESS = 2.0 TYP. RADIUS = 2.0

LTR.	REVISIONS	DATE
≠	*****	00-00-98

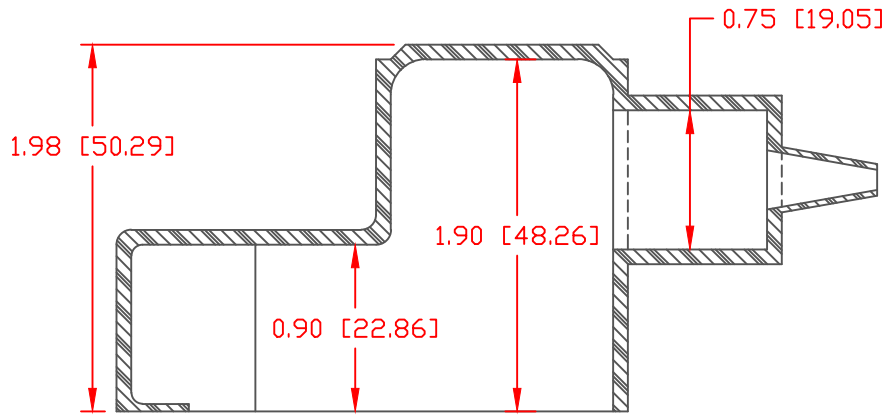

SECTION A-A

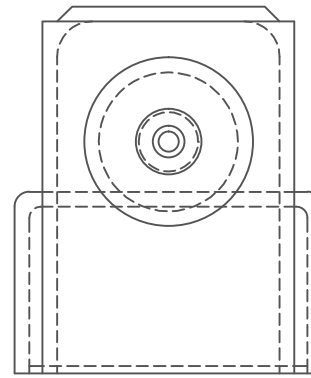

SEAL NO. 1 SHOWN

SEAL OPTIONS

SEAL THICKNESS = .8

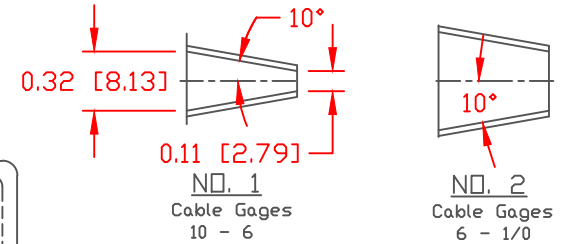

NO. 1  
Cable Gages  
10 - 6

NO. 2  
Cable Gages  
6 - 1/0

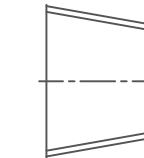

NO. 3  
Cable Gages  
1/0 - 4/0

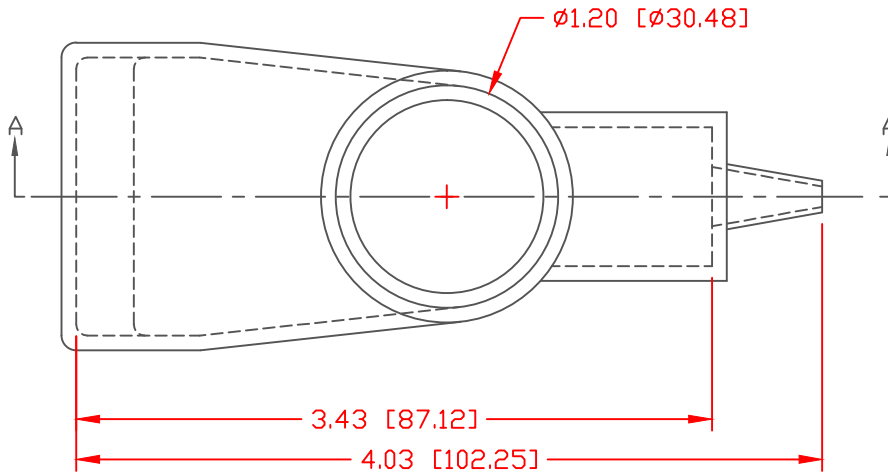

TOLERANCE UNLESS OTHERWISE SPECIFIED: ±.030"/±0.8mm  
RADIAL DIAMETERS TO BE MEASURED OVER MANDRELS,  
RING GAGES OR PIN GAGES OF SUITABLE SIZE

VTE Material Part No:	1101700114
Material:	BLACK PVC
Material Part No:	M1170-FR or Equivalent
Max. Operating Temp:	105 C
Shore Durometer:	"A" 15 SEC. 70+/-5
Specific Gravity:	1.34
Ult. Elongation %:	275 Minimum
Tensile Strength PSI:	1600 PSI Minimum
U.L. Rating:	94 V0

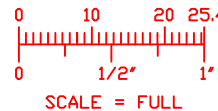

**VTE Incorporated**  
 5437 Robinson Road, P.O. Box 790  
 Pellston, Michigan 49769  
 Telephone: 1-800-527-9256, 231-539-8000  
 FAX: 231-539-0914

REF:	DATE: 3-31-98	DRN BY: JC CHK'D BY:	WEIGHT: 071 LBS. / 31.9 G.
TITLE: MARINE ADAPTER WING NUT BOOT			
MATERIAL:		PART NO. 457N1F14	
COLOR:	DRG CLASS		