

PROPRIETARY RIGHTS ARE CLAIMED FOR THE MATERIAL DISCLOSED IN THIS DRAWING.

TYP. WALL THICKNESS = 2.0 TYP. RADIUS = 2.0

LTR.	REVISIONS	DATE
≠	*****	00-00-98

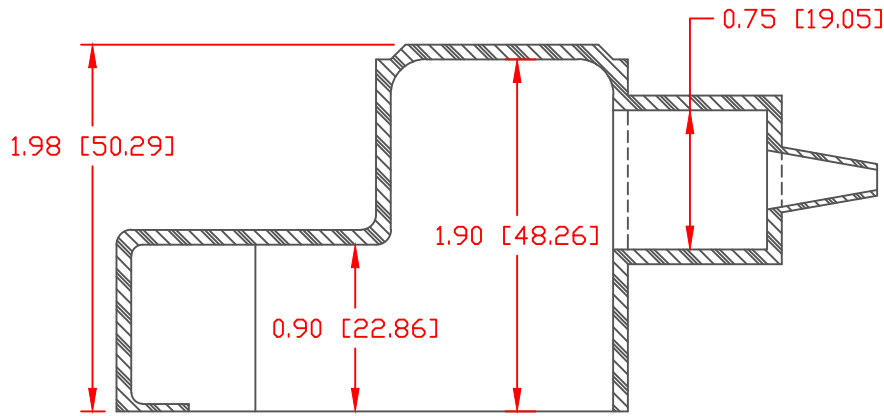

SECTION A-A

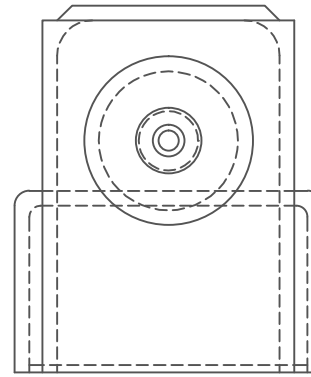

SEAL NO. 1 SHOWN

SEAL OPTIONS

SEAL THICKNESS = .8

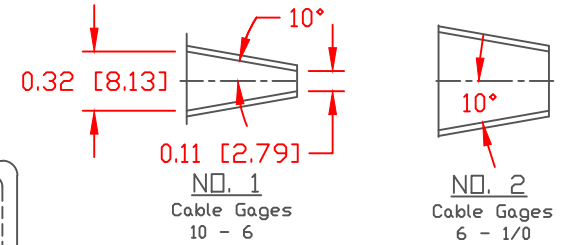

NO. 1
Cable Gages
10 - 6

NO. 2
Cable Gages
6 - 1/0

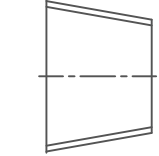

NO. 3
Cable Gages
1/0 - 4/0

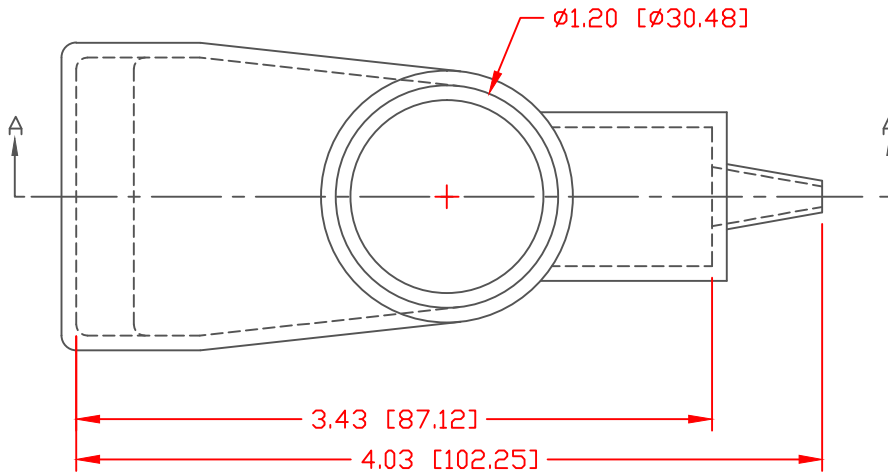

TOLERANCE UNLESS OTHERWISE SPECIFIED: $\pm 0.030''/\pm 0.8\text{mm}$
 RADIAL DIAMETERS TO BE MEASURED OVER MANDRELS,
 RING GAGES OR PIN GAGES OF SUITABLE SIZE

VTE Material Part No: 1101650102
 Material: RED PVC
 Material Part No: 9812-65-RED683
 Max. Operating Temp: 105 C
 Shore Durometer "A" 10 SEC. 67/62
 Specific Gravity: 1.34
 Ult. Elongation %: 475
 Brittle Temp: -44 C
 Tensile Strength PSI: 1547 PSI

U.L. Rating: 94 V2
 MEETS: FMVSS.302

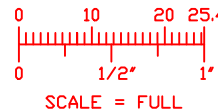

VTE Incorporated
 5437 Robinson Road, P.O. Box 790
 Pellston, Michigan 49769
 Telephone: 1-800-527-9256, 231-539-8000
 FAX: 231-539-0914

REF:	DATE: 3-31-98	DRN BY: JC CHK'D BY:	WEIGHT: 071 LBS. / 31.9 G.
TITLE: MARINE ADAPTER WING NUT BOOT			
MATERIAL:		PART NO. 457N1V02	
COLOR:	DRG CLASS		