

PROPRIETARY RIGHTS ARE CLAIMED FOR THE MATERIAL DISCLOSED IN THIS DRAWING.

TYP. WALL THICKNESS = 2.0 TYP. RADIUS = 2.0

| | | |
|------|-----------|----------|
| LTR. | REVISIONS | DATE |
| ≡ | ***** | 00-00-98 |

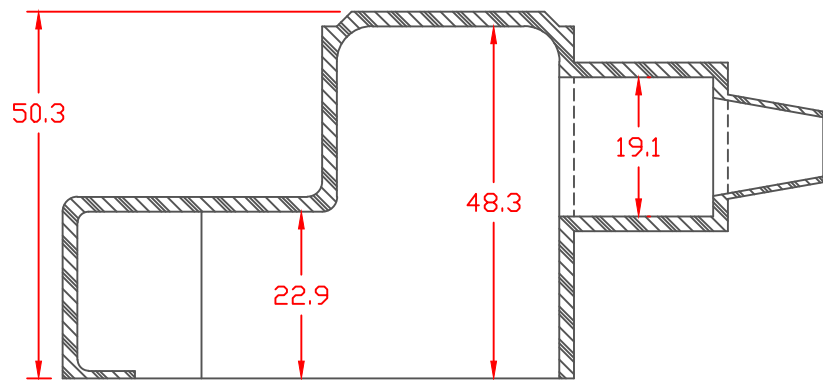

SECTION A-A

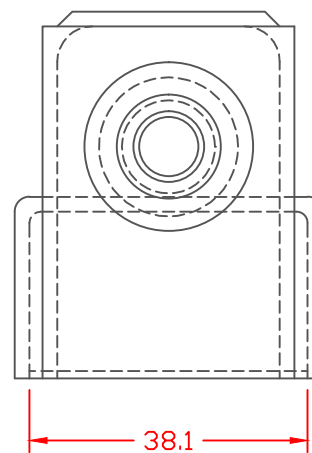

SEAL NO. 2 SHOWN

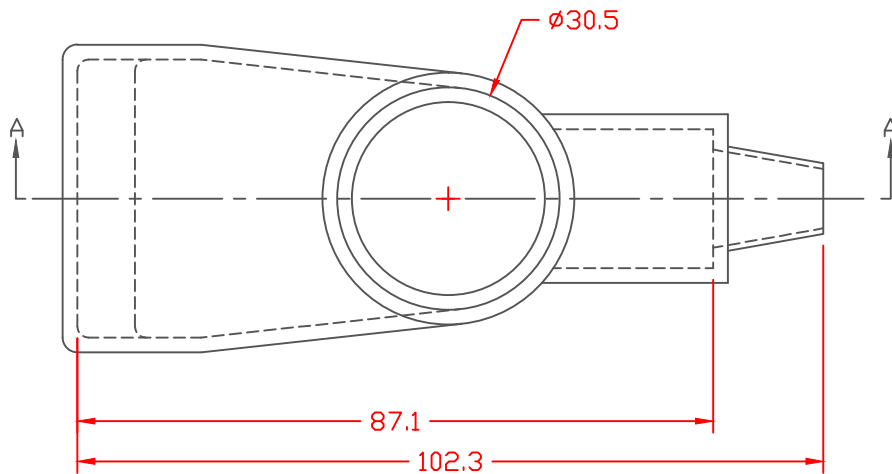

SEAL OPTIONS

SEAL THICKNESS = .8

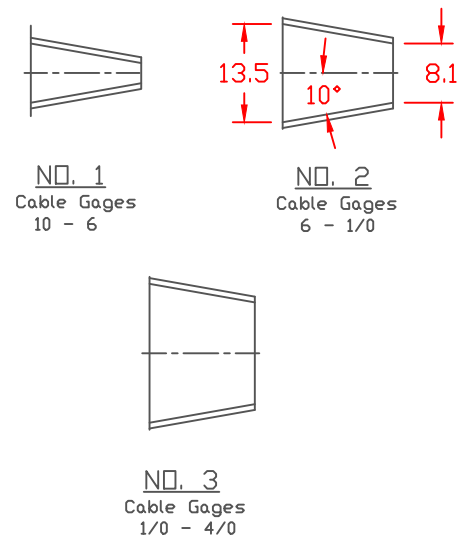

TOLERANCE UNLESS OTHERWISE SPECIFIED: ± 0.30 / ± 0.8 mm
 RADIAL DIAMETERS TO BE MEASURED OVER MANDRELS,
 RING GAGES OR PIN GAGES OF SUITABLE SIZE

| | |
|-----------------------|---------------------------|
| VTE Material Part No: | 1101700102 |
| Material: | RED PVC |
| Material Part No: | M1170 FR RD or Equivalent |
| Max. Operating Temp: | 105 C |
| Shore Durometer: | "A" 15 SEC. 70+/-5 |
| Specific Gravity: | 1.34 |
| Ult. Elongation %: | 275 Minimum |
| Tensile Strength PSI: | 1600 PSI Minimum |
| U.L. Rating: | 94 V0 |

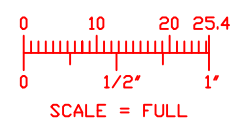

| | | | |
|-------------------------------------|---------|---|--------------------|
| | | VTE Incorporated 5437 Robinson Road, P.O. Box 790 Pellston, Michigan 49769 Telephone: 1-800-527-9256, 231-539-8000 FAX: 231-539-0914 | |
| | | REF: | DATE: |
| | 3-31-98 | CHK'D BY: | 071 LBS. / 31.9 G. |
| TITLE: MARINE ADAPTER WING NUT BOOT | | | |
| MATERIAL: | | PART NO. | |
| COLOR: | | 457N2F02 | |
| DRG CLASS | | | |