

PROPRIETARY RIGHTS ARE CLAIMED FOR THE MATERIAL DISCLOSED IN THIS DRAWING.

TYP. WALL THICKNESS = 2.0 TYP. RADIUS = 2.0

LTR.	REVISIONS	DATE
≡	*****	00-00-98

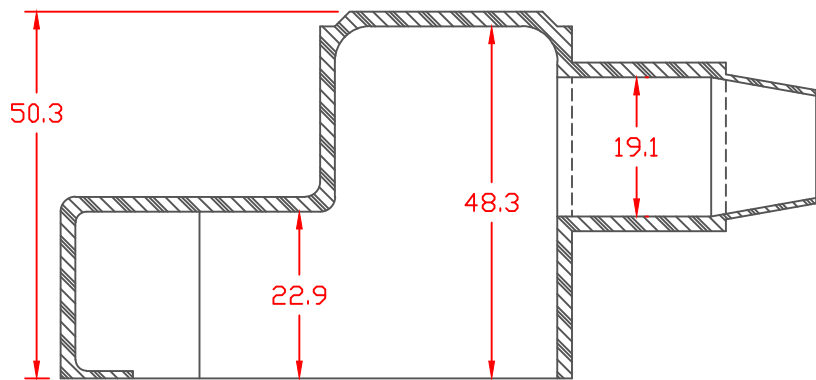

SECTION A-A

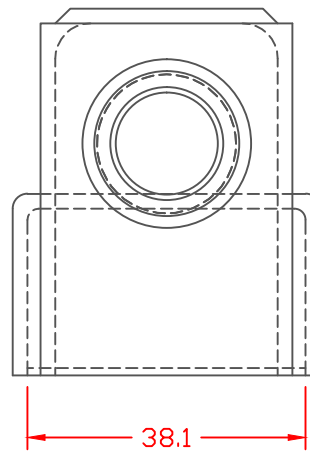

SEAL NO. 3 SHOWN

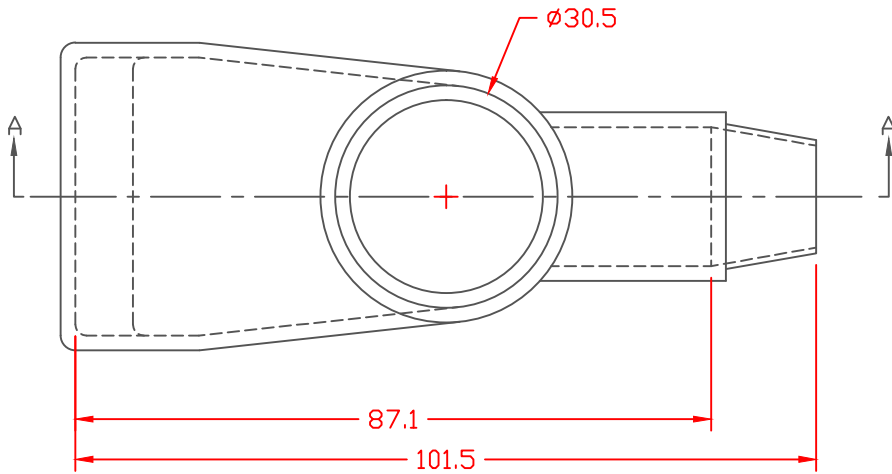

VTE Material Part No:	1101700102
Material:	RED PVC
Material Part No:	M1170 FR RD or Equivalent
Max. Operating Temp:	105 C
Shore Durometer:	"A" 15 SEC. 70+/-5
Specific Gravity:	1.34
Ult. Elongation %:	275 Minimum
Tensile Strength PSI:	1600 PSI Minimum
U.L. Rating:	94 V0

SEAL OPTIONS

SEAL THICKNESS = .8

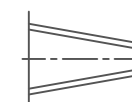

NO. 1  
Cable Gages  
10 - 6

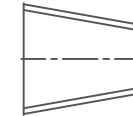

NO. 2  
Cable Gages  
6 - 1/0

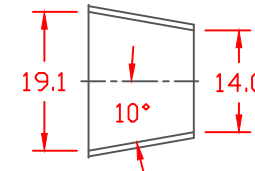

NO. 3  
Cable Gages  
1/0 - 4/0

TOLERANCE UNLESS OTHERWISE SPECIFIED: ±.030"/±0.8mm  
RADIAL DIAMETERS TO BE MEASURED OVER MANDRELS,  
RING GAGES OR PIN GAGES OF SUITABLE SIZE

	<b>VTE Incorporated</b> 5437 Robinson Road, P.O. Box 790 Pellston, Michigan 49769 Telephone: 1-800-527-9256, 231539-8000 FAX: 231-539-0914		
	REF:	DATE: 3-31-98	DRN BY: JC CHK'D BY:

TITLE: MARINE ADAPTER WING NUT BOOT	
MATERIAL:	PART NO. 457N3F02
COLOR:	DRG CLASS

