

PROPRIETARY RIGHTS ARE CLAIMED FOR THE MATERIAL DISCLOSED IN THIS DRAWING.

LTR.	REVISIONS	DATE
✂	*****	00-00-98

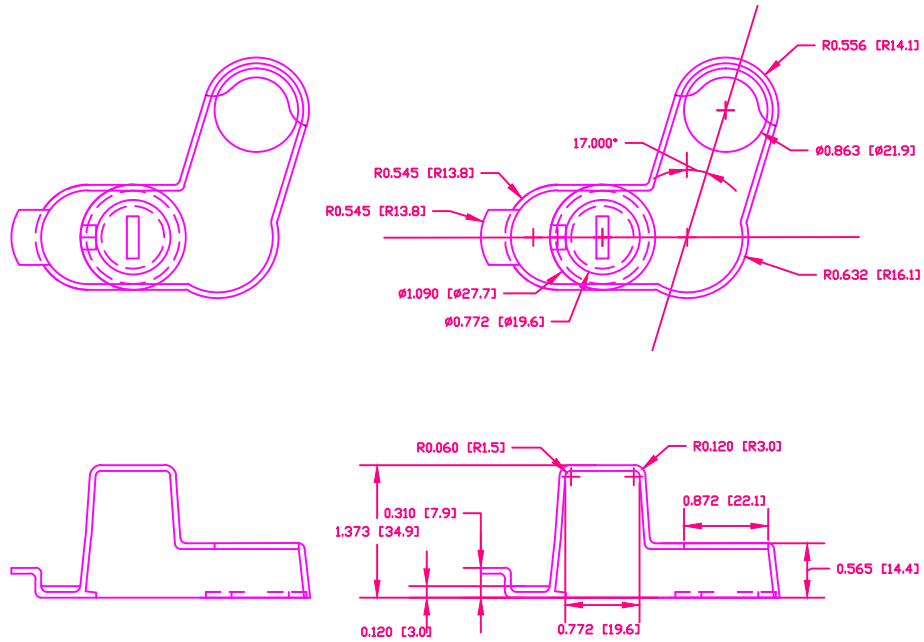

Material: RED PVC
 Material Part No 9812-65-RED683
 Max. Operating Temp: 105 C
 Shore Durometer "A" 10 SEC. 67/62
 Specific Gravity: 1.34
 Ult. Elongation %: 475
 Brittle Temp: -44 C
 Tensile Strength PSI: 1547 PSI

U.L. Rating: 94 V2
 MEETS: FMVSS.302

TOLERANCE UNLESS OTHERWISE SPECIFIED: ±.030"/±0.8mm
 RADIAL DIAMETERS TO BE MEASURED OVER MANDRELS,
 RING GAGES OR PIN GAGES OF SUITABLE SIZE

		VTE Incorporated 5437 Robinson Road, P.O. Box 790 Pellston, Michigan 49769 Telephone: 1-800-527-9256, 231-539-8000 FAX: 231-539-0914	
REF: *****	DATE: 00-00-98	DRN BY: *****	WEIGHT: *****
TITLE: *****		CHK'D BY:	SCALE: *****
MATERIAL: SEE NOTES	PART NO. 461N9V02		
COLOR: RED	DRG CLASS *****		

