

THE INFORMATION CONTAINED IN THIS DRAWING IS THE SOLE PROPERTY OF VTE INCORPORATED. ANY REPRODUCTION IN PART OR WHOLE WITHOUT THE WRITTEN PERMISSION OF VTE INCORPORATED IS PROHIBITED.

LTR.	REVISIONS	DATE
*	***	***

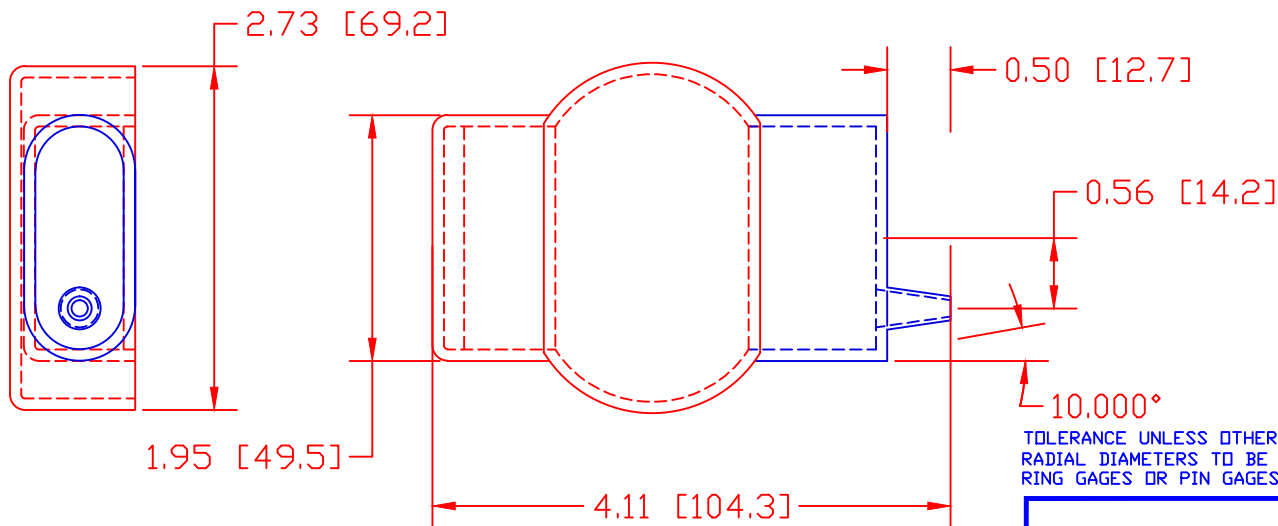
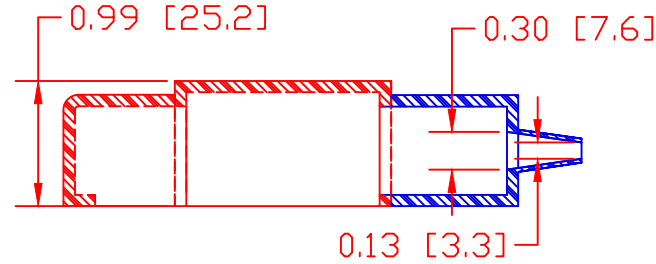

TOLERANCE UNLESS OTHERWISE SPECIFIED:  $\pm 0.030'' / \pm 0.8\text{mm}$   
 RADIAL DIAMETERS TO BE MEASURED OVER MANDRELS,  
 RING GAGES OR PIN GAGES OF SUITABLE SIZE

VTE Material Part No:  
 Material:  
 Material Part No  
 Max. Operating Temp:  
 Shore Durometer  
 Specific Gravity:  
 Ult. Elongation %:  
 Brittle Temp:  
 Tensile Strength PSI:  
 Dielectric Strength, v./ml  
 U.L. Rating:  
 MEETS:

1101650109  
 BLUE PVC  
 05-916R  
 105 C  
 "A" 65  
 1.27  
 325  
 \*\*\*\*  
 1500 PSI  
 \*\*\*\*  
 \*\*\*\*  
 \*\*\*\*



VTE Incorporated  
 5437 Robinson Road, P.O. Box 790  
 Pellston, Michigan 49769  
 Telephone: 1-800-527-9256, 231-539-8000  
 FAX: 231-539-0914

REF:	DATE:	DRN BY:	BRH	WEIGHT:
OK26900-3	06-JUN-01	CHK'D BY:	BRH	***
TITLE: BATTERY TERMINAL INSULATOR				SCALE: NOTED
MATERIAL: NOTED			PART NO.	
COLOR: NOTED	DRG CLASS	***	466L1V09	