

THE INFORMATION CONTAINED IN THIS DRAWING IS THE SOLE PROPERTY OF VTE INCORPORATED. ANY REPRODUCTION IN PART OR WHOLE WITHOUT THE WRITTEN PERMISSION OF VTE INCORPORATED IS PROHIBITED.

LTR.	REVISIONS	DATE
*	***	***

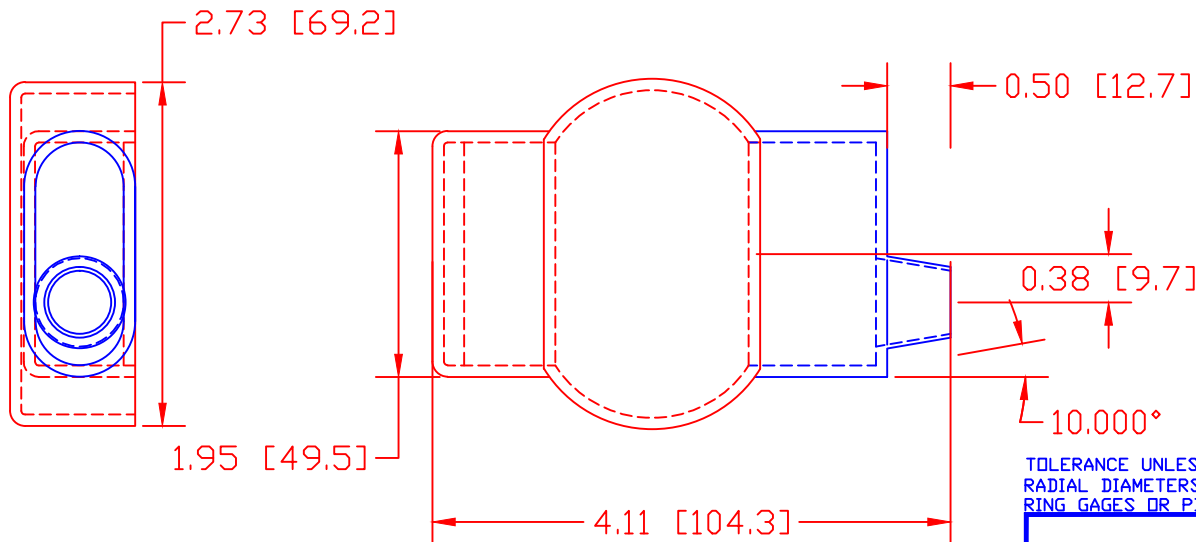
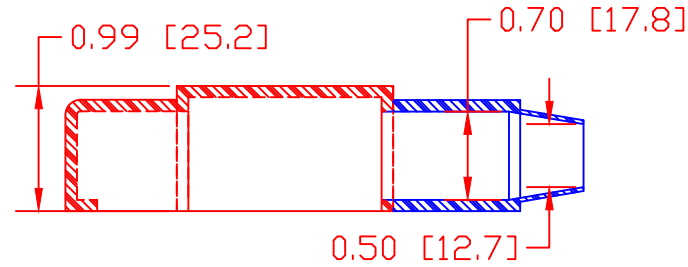

TOLERANCE UNLESS OTHERWISE SPECIFIED: ± 0.30 / ± 0.8 mm
 RADIAL DIAMETERS TO BE MEASURED OVER MANDRELS,
 RING GAGES OR PIN GAGES OF SUITABLE SIZE

VTE Material Part No:
 Material:
 Material Part No
 Max. Operating Temp:
 Shore Durometer
 Specific Gravity:
 Ult. Elongation %:
 Tensile Strength PSI:
 U.L. Rating:

1101700114
 BLACK PVC
 M1170-FR or Equivalent
 105 C
 "A" 15 SEC. 70+/-5
 1.34
 275 Minimum
 1600 PSI Minimum
 94 V0



VTE Incorporated
 5437 Robinson Road, P.O. Box 790
 Pellston, Michigan 49769
 Telephone: 1-800-527-9256, 231-539-8000
 FAX: 231-539-0914

REF:	DATE:	DRN BY:	BRH	WEIGHT:
OK26900-3	06-JUN-01	CHK'D BY:	BRH	078 LBS. / 35.4 G.
TITLE: BATTERY TERMINAL INSULATOR				SCALE: NOTED
MATERIAL: NOTED			PART NO.	
COLOR: NOTED	DRG CLASS: ***	466L3F14		