

PROPRIETARY RIGHTS ARE CLAIMED FOR THE MATERIAL DISCLOSED IN THIS DRAWING.

LTR.	REVISIONS	DATE
≠	*****	00-00-98

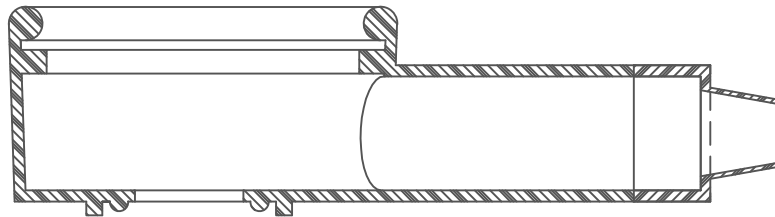
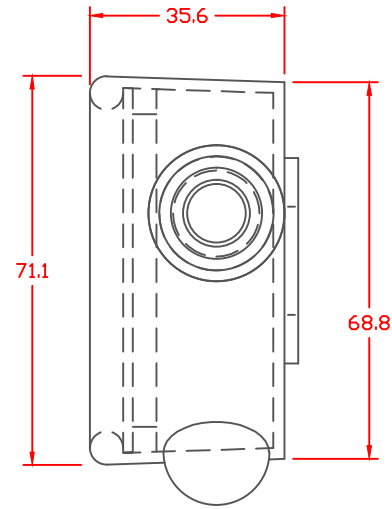
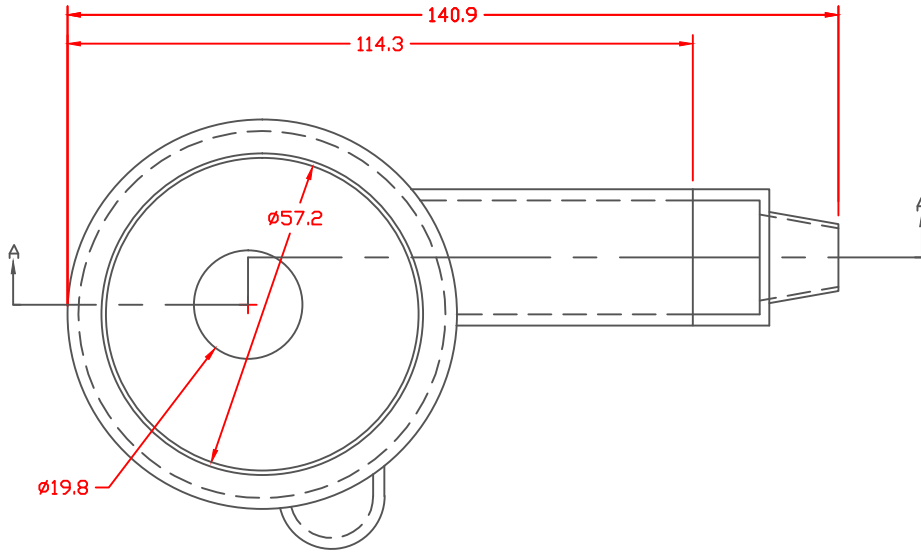

SECTION A-A

SEAL
SEAL THICKNESS = .8

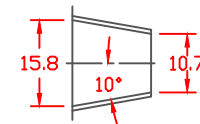

Cable Gages

TOLERANCE UNLESS OTHERWISE SPECIFIED: $\pm .030$ / ± 0.8 mm
RADIAL DIAMETERS TO BE MEASURED OVER MANDRELS,
RING GAGES OR PIN GAGES OF SUITABLE SIZE

TYP. WALL THICKNESS = 2.0
TYP. RADIUS = 2.0

VTE Material Part No:	1101700102
Material:	RED PVC
Material Part No:	M1170 FR RD or Equivalent
Max. Operating Temp:	105 C
Shore Durometer:	"A" 15 SEC. 70+/-5
Specific Gravity:	1.34
Ult. Elongation %:	275 Minimum
Tensile Strength PSI:	1600 PSI Minimum
U.L. Rating:	94 V0



		VTE Incorporated 5437 Robinson Road, P.O. Box 790 Pellston, Michigan 49769 Telephone: 1-800-527-9256, 231-539-8000 FAX: 231-539-0914	
		REF:	DATE:
	3-20-98	CHK'D BY:	11 LBS. / 49.9 G.
TITLE: 8D BATTERY TERMINAL PROTECTOR			SCALE: 3/4" = 1"
MATERIAL:		PART NO.	
COLOR:		476N7F02	
DRG CLASS			