

PROPRIETARY RIGHTS ARE CLAIMED FOR THE MATERIAL DISCLOSED IN THIS DRAWING.

LTR.	REVISIONS	DATE
≠	*****	00-00-98

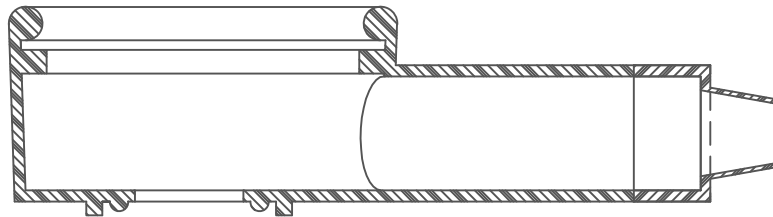
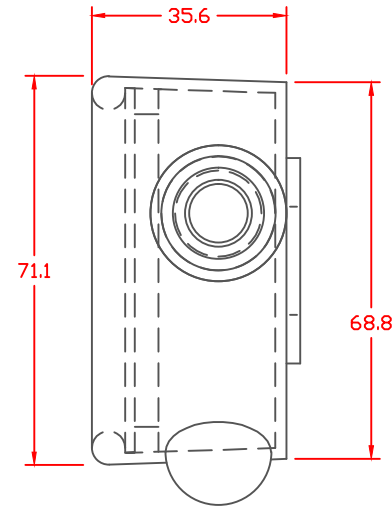
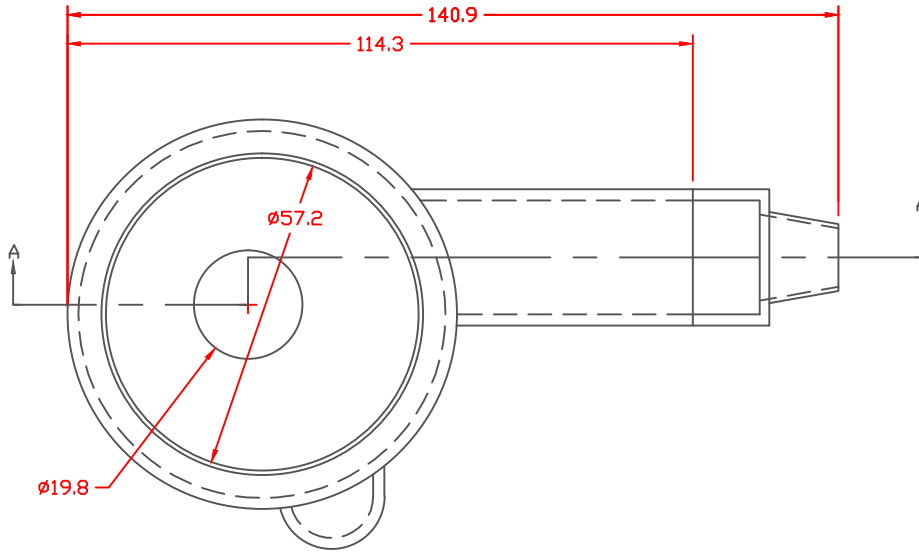

SECTION A-A

TYP. WALL THICKNESS = 2.0
TYP. RADIUS = 2.0

SEAL
SEAL THICKNESS = .8

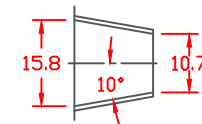

Cable Gages

TOLERANCE UNLESS OTHERWISE SPECIFIED: $\pm .030$ / ± 0.8 mm
RADIAL DIAMETERS TO BE MEASURED OVER MANDRELS,
RING GAGES OR PIN GAGES OF SUITABLE SIZE

VTE Material Part No:	1101700114
Material:	BLACK PVC
Material Part No:	M1170-FR or Equivalent
Max. Operating Temp:	105 C
Shore Durometer:	"A" 15 SEC. 70+/-5
Specific Gravity:	1.34
Ult. Elongation %:	275 Minimum
Tensile Strength PSI:	1600 PSI Minimum
U.L. Rating:	94 V0



VTE Incorporated
5437 Robinson Road, P.O. Box 790
Pellston, Michigan 49769
Telephone: 1-800-527-9256, 231-539-8000
FAX: 231-539-0914

REF:	DATE: 3-20-98	DRN BY: JC	WEIGHT: 11 LBS. / 49.9 G.
TITLE: 8D BATTERY TERMINAL PROTECTOR		CHK'D BY:	SCALE: 3/4" = 1"
MATERIAL:	PART NO. 476N7F14		
COLOR:	DRG CLASS		