

PROPRIETARY RIGHTS ARE CLAIMED FOR THE MATERIAL DISCLOSED IN THIS DRAWING.

LTR.	REVISIONS	DATE
≠	*****	00-00-98

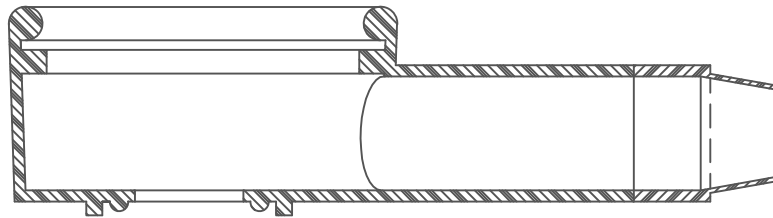
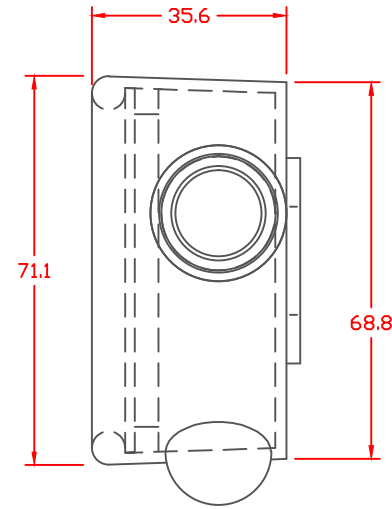
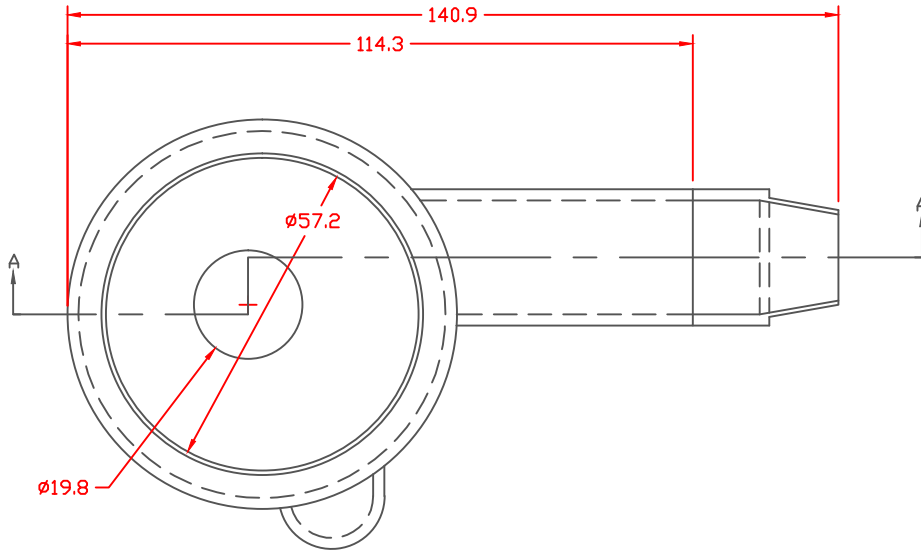

SECTION A-A

SEAL
SEAL THICKNESS = .8

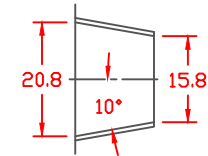

TYP. WALL THICKNESS = 2.0
TYP. RADIUS = 2.0

VTE Material Part No: 1101700102
 Material: RED PVC
 Material Part No: M1170 FR RD or Equivalent
 Max. Operating Temp: 105 C
 Shore Durometer: "A" 15 SEC. 70+/-5
 Specific Gravity: 1.34
 Ult. Elongation %: 275 Minimum
 Tensile Strength PSI: 1600 PSI Minimum
 U.L. Rating: 94 V0

TOLERANCE UNLESS OTHERWISE SPECIFIED: Cable Gages ±.030" / ±0.8mm
 RADIAL DIAMETERS TO BE MEASURED OVER MANDRELS,
 RING GAGES OR PIN GAGES OF SUITABLE SIZE

VTE Incorporated
 5437 Robinson Road, P.O. Box 790
 Pellston, Michigan 49769
 Telephone: 1-800-527-9256, 231-539-8000
 FAX: 231-539-0914

REF:	DATE: 3-20-98	DRN BY: JC	WEIGHT: .11 LBS. / 49.9 G.
TITLE: 8D BATTERY TERMINAL PROTECTOR		CHK'D BY:	SCALE: 3/4" = 1"
MATERIAL:		PART NO. 476N8F02	
COLOR:	DRG CLASS		

