

PROPRIETARY RIGHTS ARE CLAIMED FOR THE MATERIAL DISCLOSED IN THIS DRAWING.

LTR.	REVISIONS	DATE
≠	*****	00-00-98

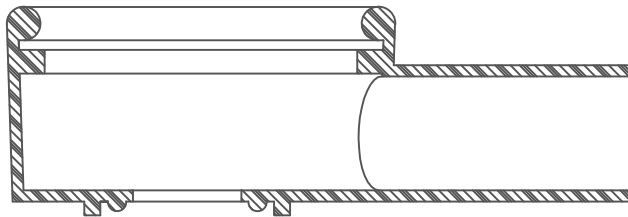
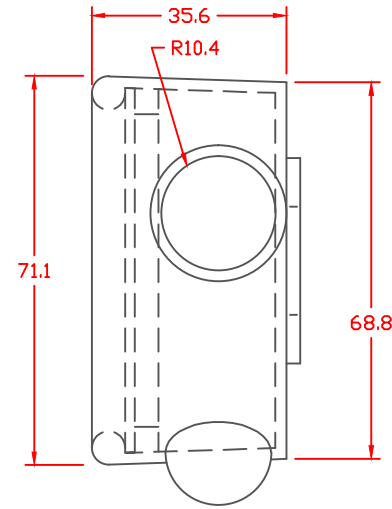
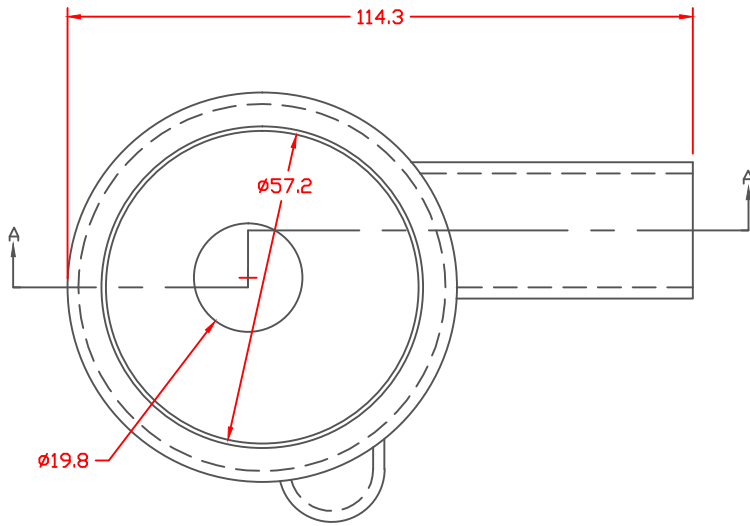

SECTION A-A

TYP. WALL THICKNESS = 2.0
TYP. RADIUS = 2.0

VTE Material Part No:	1101700102
Material:	RED PVC
Material Part No	M1170 FR RD or Equivalent
Max. Operating Temp:	105 C
Shore Durometer	"A" 15 SEC. 70+/-5
Specific Gravity:	1.34
Ult. Elongation %:	275 Minimum
Tensile Strength PSI:	1600 PSI Minimum
U.L. Rating:	94 V0

TOLERANCE UNLESS OTHERWISE SPECIFIED: ±0.30"/±0.8mm
RADIAL DIAMETERS TO BE MEASURED OVER MANDRELS,
RING GAGES OR PIN GAGES OF SUITABLE SIZE

	VTE Incorporated 5437 Robinson Road, P.O. Box 790 Pellston, Michigan 49769 Telephone: 1-800-527-9256, 231-539-8000 FAX: 231-539-0914	
	REF:	DATE: 3-20-98

DRN BY: JC	WEIGHT: .11 LBS. / 49.9 G.
CHK'D BY:	SCALE: 3/4" = 1"

TITLE: 8D BATTERY TERMINAL PROTECTOR

MATERIAL:	PART NO. 476N9F02
COLOR:	DRG CLASS

