

PROPRIETARY RIGHTS ARE CLAIMED FOR THE MATERIAL DISCLOSED IN THIS DRAWING.

LTR.	REVISIONS	DATE
≠	*****	00-00-98

TYP. RADIUS = 1.0 TYP. SEAL THICKNESS = .8

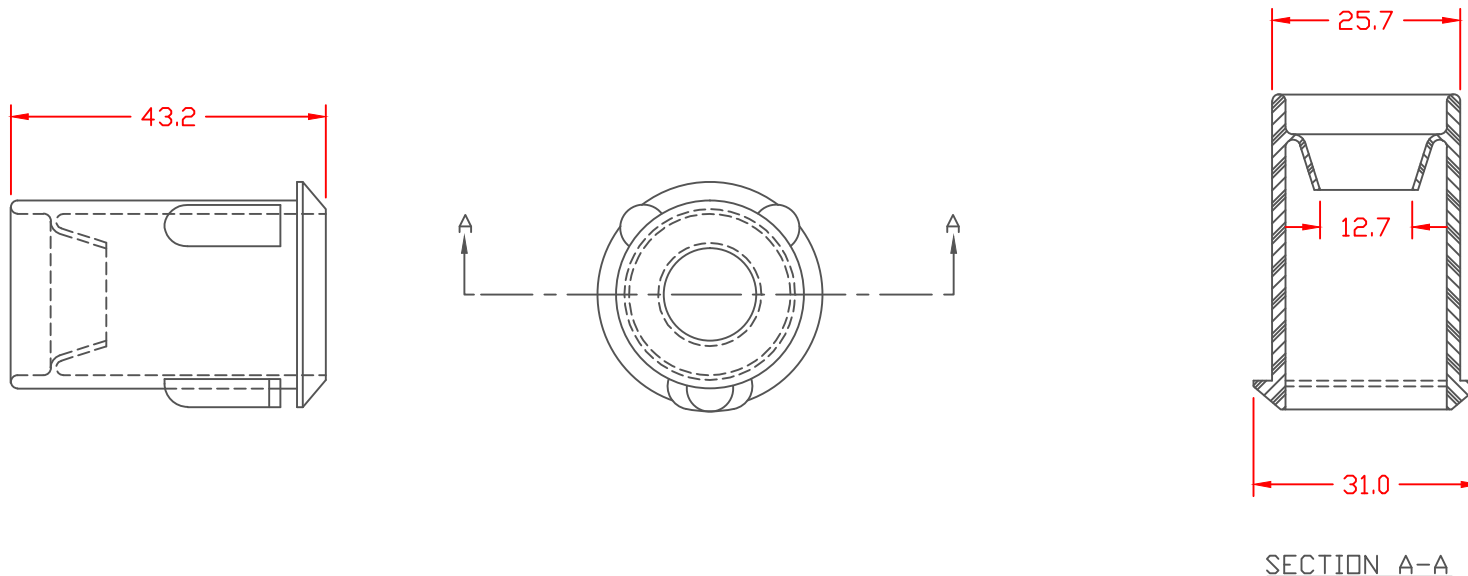



SEAL

TOLERANCE UNLESS OTHERWISE SPECIFIED: ±.030"/±0.8mm
 RADIAL DIAMETERS TO BE MEASURED OVER MANDRELS,
 RING GAGES OR PIN GAGES OF SUITABLE SIZE

VTE Material Part No:
 Material:
 Material Part No
 Max. Operating Temp:
 Shore Durometer
 Specific Gravity:
 Ult. Elongation %:
 Tensile Strength PSI:
 U.L. Rating:

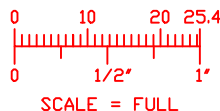
1101700114
 BLACK PVC
 M1170-FR or Equivalent
 105 C
 "A" 15 SEC. 70+/-5
 1.34
 275 Minimum
 1600 PSI Minimum
 94 V0



		VTE Incorporated 5437 Robinson Road, P.O. Box 790 Pellston, Michigan 49769 Telephone: 1-800-527-9256, 231-539-8000 FAX: 231-539-0914	
		REF:	DATE: 4-1-98
TITLE: 8D BATTERY CAP WIRE SEAL			
MATERIAL:		PART NO. 478N9F14	
COLOR:	DRG CLASS		