

PROPRIETARY RIGHTS ARE CLAIMED FOR THE MATERIAL DISCLOSED IN THIS DRAWING.

LTR.	REVISIONS	DATE
≡	*****	00-00-98

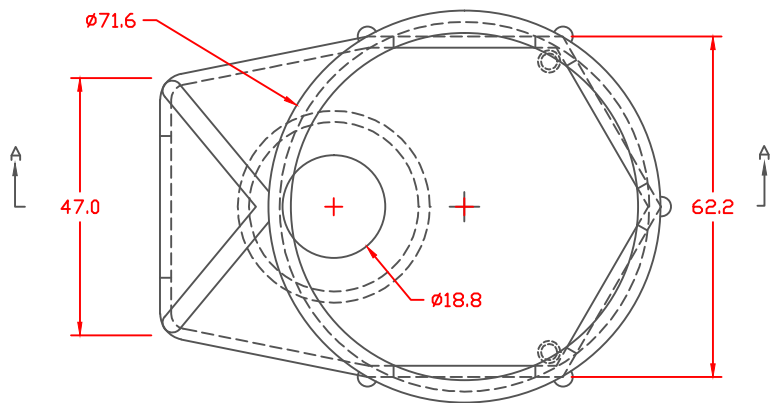

TYP. WALL THICKNESS = 2.0

NOTE
3° TAPER ON ALL VERTICAL SURFACES OVER 2.54 MM.

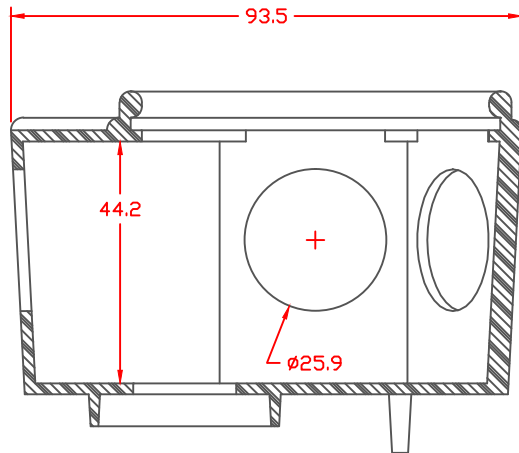

SECTION A-A

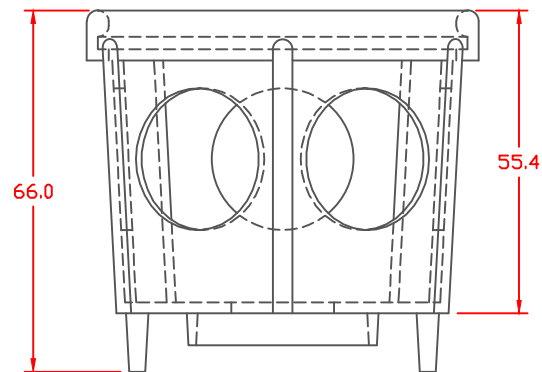

TOLERANCE UNLESS OTHERWISE SPECIFIED: ±.030"/±0.8mm
RADIAL DIAMETERS TO BE MEASURED OVER MANDRELS,
RING GAGES OR PIN GAGES OF SUITABLE SIZE

Material:	YELLOW SYLVIN
Material Part No	9067-95 YELLOW 405
Max. Operating Temp:	60 C
Durometer: Shore "A"	94
Specific Gravity:	1.49
Ult. Elongation %:	259
Brittle Temp:	-19 C
Modulus PSI:	*****
Tensile Strength PSI:	2296 PSI

MEETS: *****

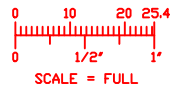

	VTE Incorporated 5437 Robinson Road, P.O. Box 790 Pellston, Michigan 49769 Telephone: 1-800-527-9256, 231-539-8000 FAX: 231-539-0914	
	REF:	DATE: 4-2-98

DRN BY: JC	WEIGHT: 65 grams
CHK'D BY:	
TITLE: 8D MARINE BATTERY TERMINAL, BOOT	
MATERIAL:	PART NO. 480N9V05
COLOR:	DRG CLASS