

PROPRIETARY RIGHTS ARE CLAIMED FOR THE MATERIAL DISCLOSED IN THIS DRAWING.

LTR.	REVISIONS	DATE
≠	*****	00-00-98

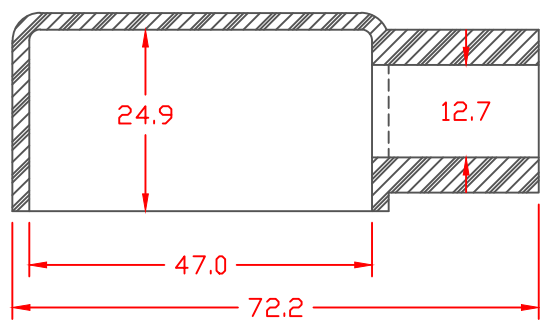
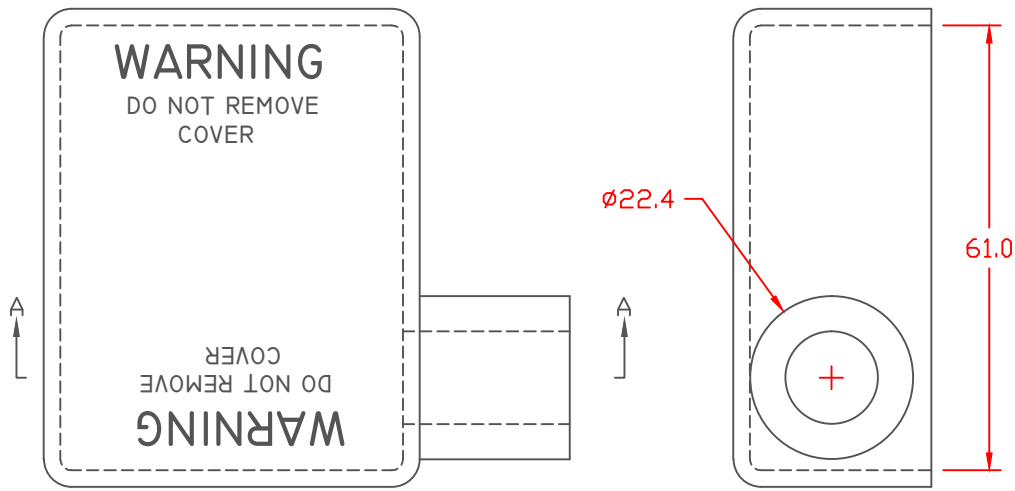

SECTION A-A

VTE Material Part No:	1101650114
Material:	BLACK PVC
Material Part No:	9812-65
Max. Operating Temp:	105 C
Shore Durometer:	"A" 10 SEC. 67/63
Specific Gravity:	1.33
Ult. Elongation %:	520
Brittle Temp:	-36 C
Tensile Strength PSI:	1563 PSI
U.L. Rating:	94 V2
MEETS:	FMVSS.302



TYP. WALL THICKNESS = 2.3

TOLERANCE UNLESS OTHERWISE SPECIFIED: ±.030"/±0.8mm
 RADIAL DIAMETERS TO BE MEASURED OVER MANDRELS,
 RING GAGES OR PIN GAGES OF SUITABLE SIZE

		VTE Incorporated 5437 Robinson Road, P.O. Box 790 Pellston, Michigan 49769 Telephone: 1-800-527-9256, 231-539-8000 FAX: 231-539-0914	
		REF:	DATE:
	4-6-98	CHK'D BY:	078 LBS. / 35.5 G
TITLE: BATTERY CABLE BOOT			
MATERIAL:		PART NO. RIGHT HAND	
COLOR:		500R7 V14	
DRG CLASS			