

PROPRIETARY RIGHTS ARE CLAIMED FOR THE MATERIAL DISCLOSED IN THIS DRAWING.  
 TYP. WALL THICKNESS = 1.5

LTR.	REVISIONS	DATE
≠	*****	00-00-98

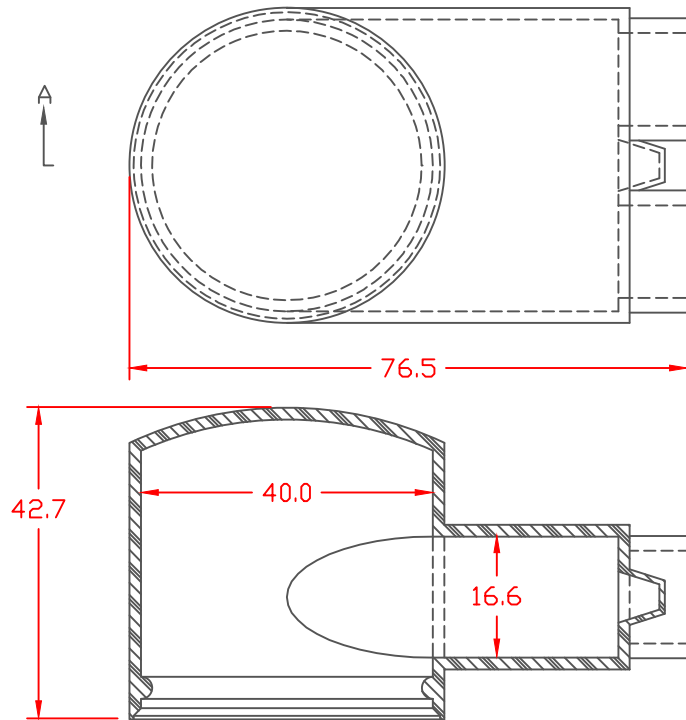

SECTION A-A

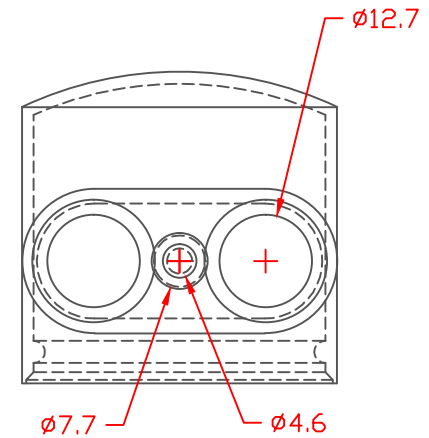

TOLERANCE UNLESS OTHERWISE SPECIFIED:  $\pm 0.30 / \pm 0.8\text{mm}$   
 RADIAL DIAMETERS TO BE MEASURED OVER MANDRELS,  
 RING GAGES OR PIN GAGES OF SUITABLE SIZE

VTE Material Part No: 1101650102  
 Material: RED PVC  
 Material Part No: 9812-65-RED683  
 Max. Operating Temp: 105 C  
 Shore Durometer "A" 10 SEC. 67/62  
 Specific Gravity: 1.34  
 Ult. Elongation %: 475  
 Brittle Temp: -44 C  
 Tensile Strength PSI: 1547 PSI

U.L. Rating: 94 V2  
 MEETS: FMVSS.302

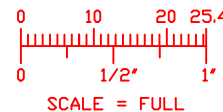

		<b>VTE Incorporated</b> 5437 Robinson Road, P.O. Box 790 Pellston, Michigan 49769 Telephone: 1-800-527-9256, 231-539-8000 FAX: 231-539-0914	
		REF:	DATE: 4-8-98
TITLE: STYLE 4 MARINE BOOT-UPPER		CHK'D BY:	
MATERIAL:		PART NO. 600N4V02	
COLOR:	DRG CLASS		