

PROPRIETARY RIGHTS ARE CLAIMED FOR THE MATERIAL DISCLOSED IN THIS DRAWING.

TYP. WALL THICKNESS = 1.5

LTR.	REVISIONS	DATE
≠	*****	00-00-98

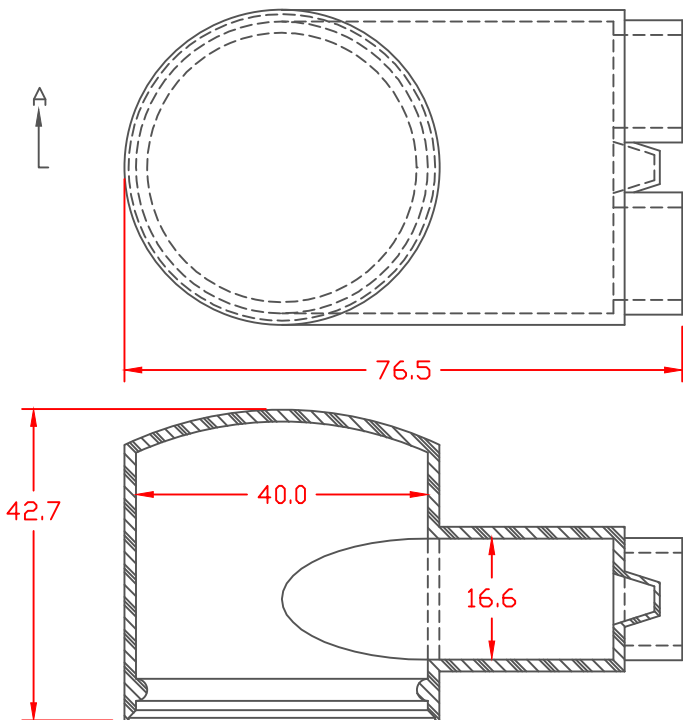

SECTION A-A

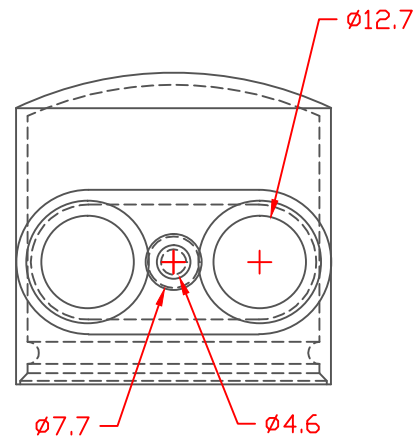

TOLERANCE UNLESS OTHERWISE SPECIFIED: $\pm 0.30 / \pm 0.8\text{mm}$
 RADIAL DIAMETERS TO BE MEASURED OVER MANDRELS,
 RING GAGES OR PIN GAGES OF SUITABLE SIZE

VTE Material Part No: 1101650114
 Material: BLACK PVC
 Material Part No: 9812-65
 Max. Operating Temp: 105 C
 Shore Durometer: "A" 10 SEC. 67/63
 Specific Gravity: 1.33
 Ult. Elongation %: 520
 Brittle Temp: -36 C
 Tensile Strength PSI: 1563 PSI

U.L. Rating: 94 V2
 MEETS: FMVSS.302

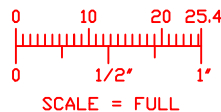

		VTE Incorporated 5437 Robinson Road, P.O. Box 790 Pellston, Michigan 49769 Telephone: 1-800-527-9256, 231-539-8000 FAX: 231-539-0914	
		REF:	DATE: 4-8-98
TITLE: STYLE 4 MARINE BOOT-UPPER			
MATERIAL:		PART NO. 600N4 V14	
COLOR:	DRG CLASS		