

PROPRIETARY RIGHTS ARE CLAIMED FOR THE MATERIAL DISCLOSED IN THIS DRAWING.

TYP. WALL THICKNESS = 1.5

LTR.	REVISIONS	DATE
≠	*****	00-00-98

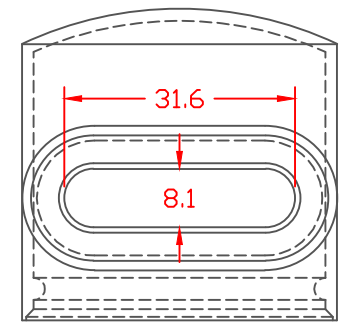
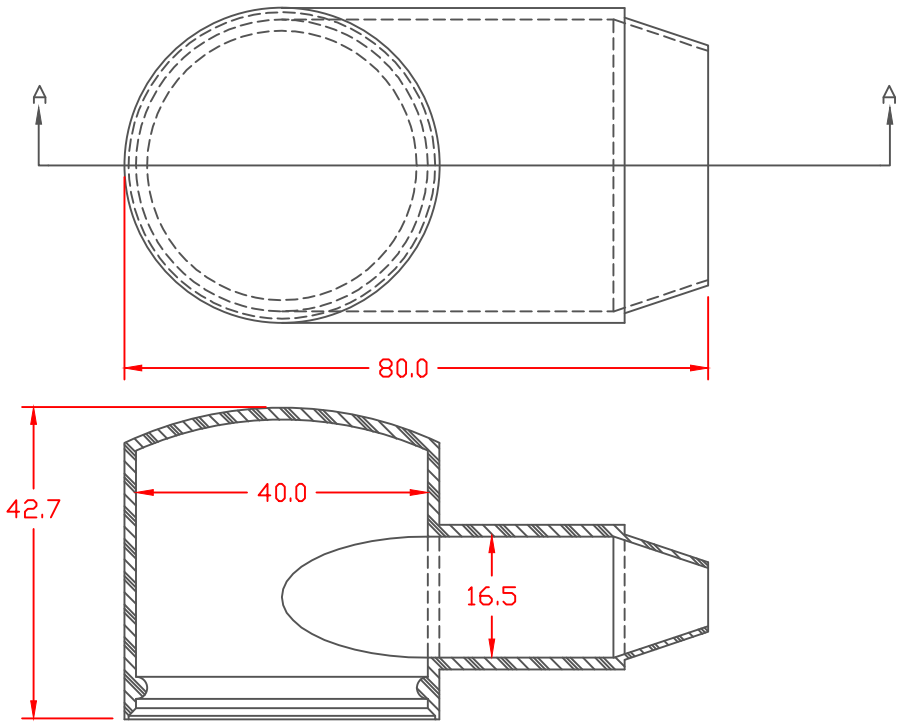

SECTION A-A

TOLERANCE UNLESS OTHERWISE SPECIFIED: ± 0.30 / ± 0.8 mm
 RADIAL DIAMETERS TO BE MEASURED OVER MANDRELS,
 RING GAGES OR PIN GAGES OF SUITABLE SIZE

Material:
 Material Part No

Thermoplastic Elastomer
 (Santoprene 201-64 or Equivalent)
 Durometer 67 to 73 Shore A



VTE Incorporated
 5437 Robinson Road, P.O. Box 790
 Pellston, Michigan 49769
 Telephone: 1-800-527-9256, 231-539-8000
 FAX: 231-539-0914

REF:	DATE: 4-8-98	DRN BY: JC CHK'D BY:	WEIGHT: 053 LBS. / 23.9 G.
------	-----------------	-------------------------	-------------------------------

TITLE: **STYLE 7 MARINE BOOT-UPPER**

MATERIAL:	PART NO. 600N7 T02
COLOR:	DRG CLASS

