

THE INFORMATION CONTAINED IN THIS DRAWING IS THE SOLE PROPERTY OF VTE INCORPORATED. ANY REPRODUCTION IN PART OR WHOLE WITHOUT THE WRITTEN PERMISSION OF VTE INCORPORATED IS PROHIBITED.

LTR.	REVISIONS	DATE	INT.
△	3842-002 WAS 3842	19MAY05	BRH
⊞	REPLACED P/N 3842-002 WITH P/N 3842-005	14APR16	RAS

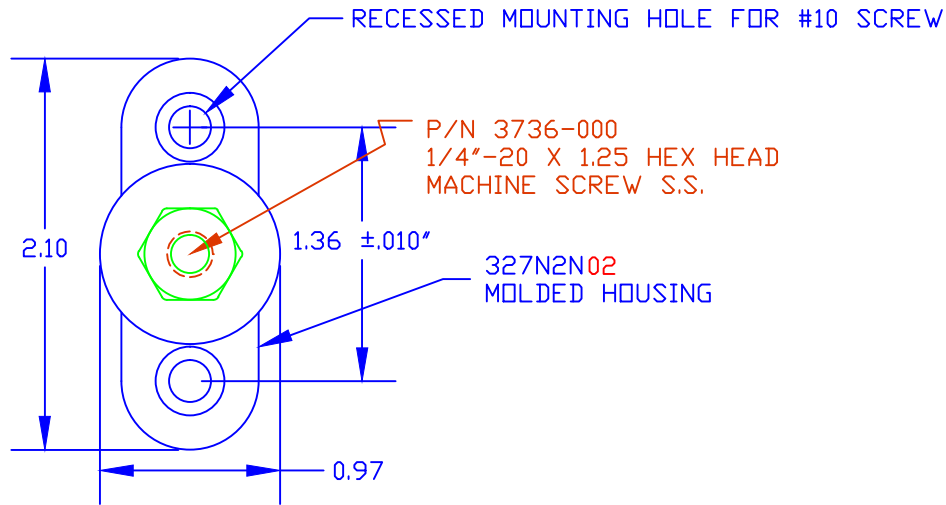

DO NOT  
SCALE

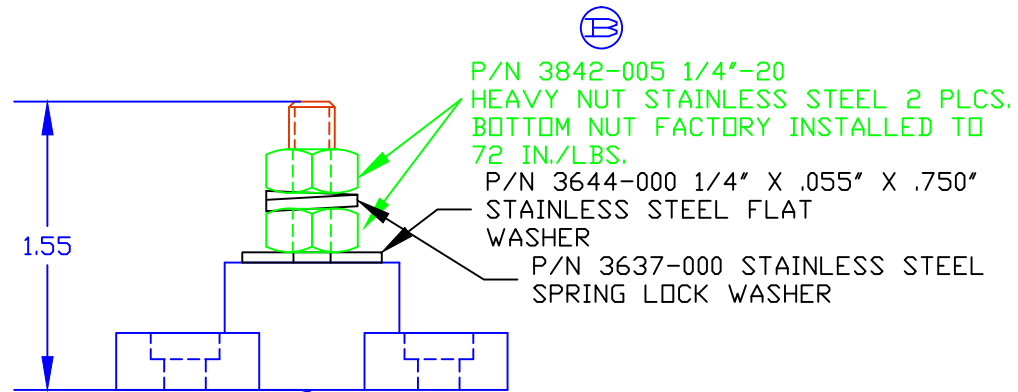
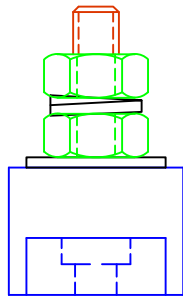

TOLERANCE UNLESS OTHERWISE SPECIFIED: ±.030"/±0.8mm  
RADIAL DIAMETERS TO BE MEASURED OVER MANDRELS,  
RING GAGES OR PIN GAGES OF SUITABLE SIZE

BASE MATERIAL: GLASS-REINFORCED NYLON  
 BASE MATERIAL U.L. RATING: 94 HB  
 DIELECTRIC STRENGTH: 630 VOLTS/MIL PER ASTM D149  
 CURRENT RATING: 165 AMPS  
 TEMP. RISE AT LOAD: 52 DEG. F.  
 MAXIMUM RECOMMENDED TORQUE: 60 IN./LBS.



VTE Incorporated  
 5437 Robinson Road, P.O. Box 790  
 Pellston, Michigan 49769  
 Telephone: 1-800-527-9256, 231-539-8000  
 FAX: 231-539-0914

REF: *****	DATE: 09APR03	DRN BY: BRH	WEIGHT: *****
TITLE: 1/4" SMALL JUNCTION STUD			SCALE:
MATERIAL:		PART NO.	
COLOR: RED	DRG CLASS: *****	77025-XN02	