

THE INFORMATION CONTAINED IN THIS DRAWING IS THE SOLE PROPERTY OF VTE INCORPORATED. ANY REPRODUCTION IN PART OR WHOLE WITHOUT THE WRITTEN PERMISSION OF VTE INCORPORATED IS PROHIBITED.

LTR.	REVISIONS	DATE	INT.
A	ADDED MATERIAL AND PERFORMANCE NOTES	22JAN04	BRH
B	REVISED PERFORMANCE NOTES	23FEB04	BRH
C	3844-002 WAS 3844	18MAY05	BRH
D	REPLACED (1)-3844-002 WITH (1)-3844-000	01SEP05	BRH

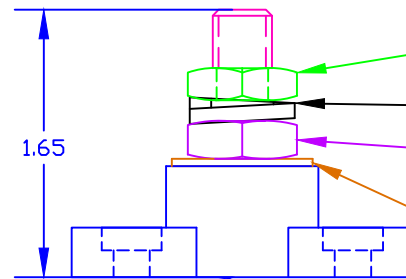
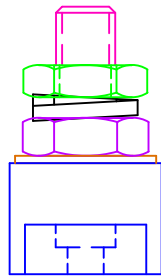
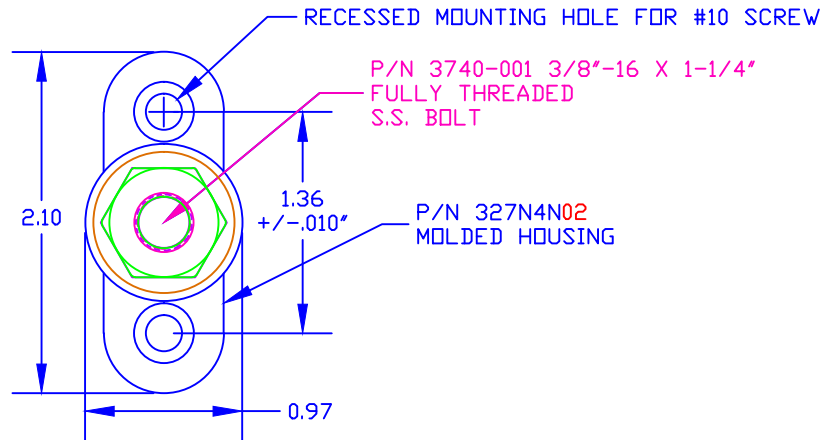

P/N 329N0V02
CAVITY PLUG

DO NOT
SCALE

OPTIONAL CONSTRUCTION NOTE:
COLOR OF BOLT CAVITY PLUG
ON BOTTOM OF ASSEMBLY MAY VARY

P/N 3844-000 3/8"-16 HEAVY HEX
NUT STAINLESS STEEL 2 PLCS.
FACTORY ASSEMBLED TO 15 FT./LBS (180 IN./LBS)

P/N 3638-000 3/8" STAINLESS STEEL
SPRING WASHER

P/N 3844-000 3/8"-16 TIN PLATED BRASS
HEAVY HEX JAM NUT FACTORY
ASSEMBLED TO 15 FT./LBS (180 IN./LBS) ⓓ

P/N 3646-000 3/8" STAINLESS FLAT WASHER

TOLERANCE UNLESS OTHERWISE SPECIFIED: ±.030"/±0.8mm
RADIAL DIAMETERS TO BE MEASURED OVER MANDRELS,
RING GAGES OR PIN GAGES OF SUITABLE SIZE

BASE MATERIAL: GLASS-REINFORCED NYLON
BASE MATERIAL U.L. RATING: 94 HB
DIELECTRIC STRENGTH: 630 VOLTS/MIL PER ASTM D149
CURRENT RATING: 250 AMPS
TEMP. RISE AT LOAD: 52 DEG. F.
RECOMMENDED MAXIMUM TORQUE: 12 FT./LBS. (144 IN./LBS.)



VTE Incorporated
5437 Robinson Road, P.O. Box 790
Pellston, Michigan 49769
Telephone: 1-800-527-9256, 231-539-8000
FAX: 231-539-0914

REF: ****	DATE: 09APR03	DRN BY: BRH	WEIGHT: ****
TITLE: 3/8" SMALL JUNCTION POST			SCALE: NONE
MATERIAL: NOTED		PART NO.	
COLOR: RED	DRG CLASS	77037-N02 X	