

THE INFORMATION CONTAINED IN THIS DRAWING IS THE SOLE PROPERTY OF VTE INCORPORATED. ANY REPRODUCTION IN PART OR WHOLE WITHOUT THE WRITTEN PERMISSION OF VTE INCORPORATED IS PROHIBITED.

LTR.	REVISIONS	DATE	INT.
A	3843-002 WAS 3843	19MAY05	BRH
B	REPLACED P/N 3843-001 WITH P/N 3843-008	30MAR16	RAS

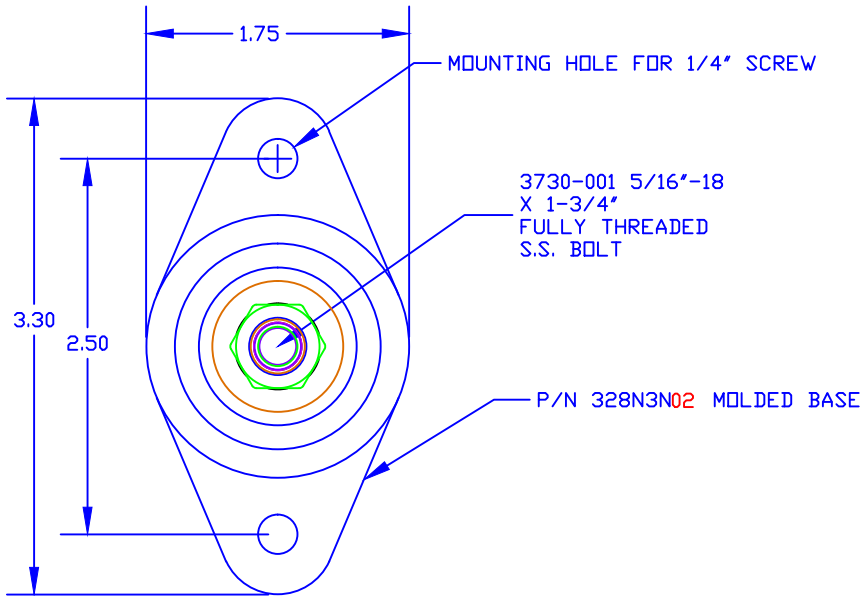

DO NOT SCALE

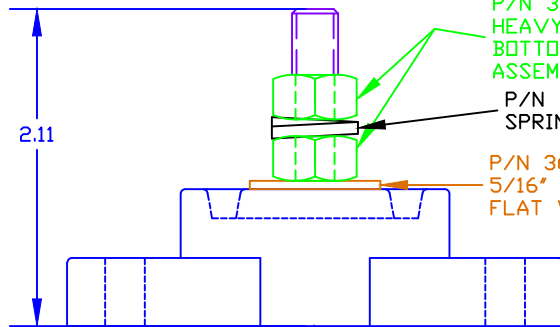
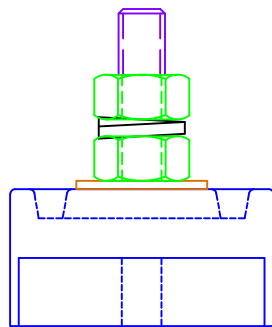

- P/N 3843-008 5/16"-18 HEAVY NUT STAINLESS STEEL 2 PLCS. BOTTOM NUT FACTORY ASSEMBLED TO 12 FT./LBS. (144 IN./LBS.)
- P/N 3642-000 STAINLESS STEEL SPRING LOCK WASHER
- P/N 3645-000 5/16" STAINLESS STEEL FLAT WASHER

P/N 329N0V02 CAVITY PLUG (NOT SHOWN)

TOLERANCE UNLESS OTHERWISE SPECIFIED: ±0.030"/±0.8mm  
 RADIAL DIAMETERS TO BE MEASURED OVER MANDRELS,  
 RING GAGES OR PIN GAGES OF SUITABLE SIZE

BASE MATERIAL: GLASS-REINFORCED NYLON  
 BASE MATERIAL U.L. RATING: 94 HB  
 DIELECTRIC STRENGTH: 630 VOLTS/MIL PER ASTM D149  
 CURRENT RATING: 165 AMPS  
 TEMP. RISE AT LOAD: 52 DEG. F.  
 BREAKOUT TORQUE: 22 FT./LBS. (264 IN./LBS.)  
 RECOMMENDED MAXIMUM TORQUE: 10 FT./LBS. (120 IN./LBS.)

VTE Incorporated  
 5437 Robinson Road, P.O. Box 790  
 Pellston, Michigan 49769  
 Telephone: 1-800-527-9256, 231-539-8000  
 FAX: 231-539-0914

REF: ***	DATE: 09APR03	DRN BY: BRH	WEIGHT: ***
TITLE: 5/16" POWER DISTRIBUTION STUD			SCALE:
MATERIAL:		PART NO.	
COLOR:	DRG CLASS: ***	77131-XN02	