

PROPRIETARY RIGHTS ARE CLAIMED FOR THE MATERIAL DISCLOSED IN THIS DRAWING.

TYP. WALL THICKNESS = 1.5

LTR.	REVISIONS	DATE
≡	*****	00-00-98

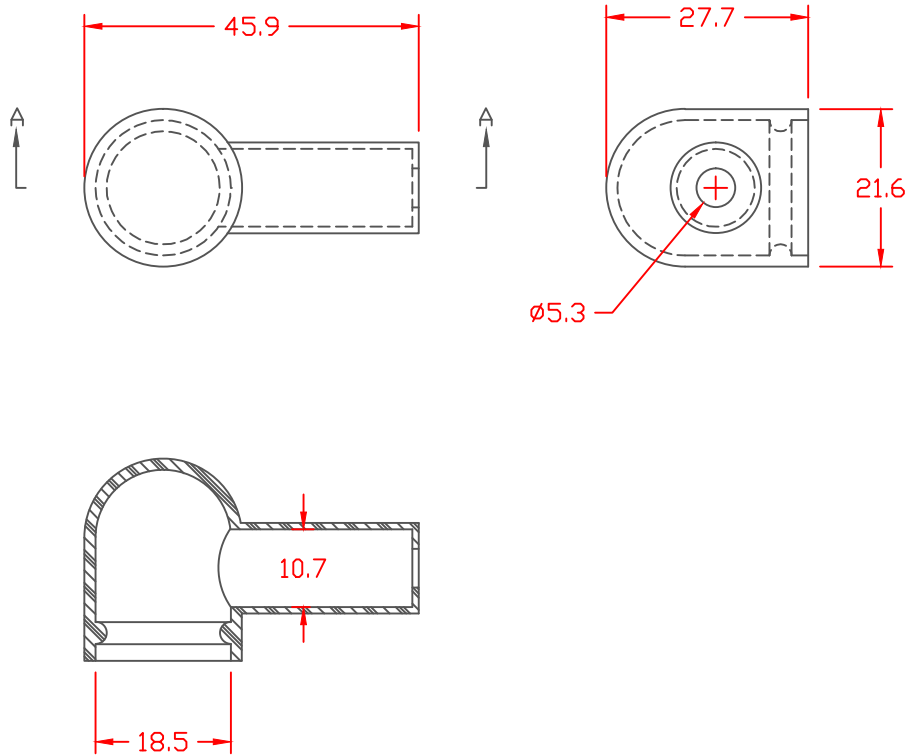

SECTION A-A

TOLERANCE UNLESS OTHERWISE SPECIFIED: ±.030"/±0.8mm
 RADIAL DIAMETERS TO BE MEASURED OVER MANDRELS,
 RING GAGES OR PIN GAGES OF SUITABLE SIZE

VTE Material Part No:
 Material:
 Material Part No:
 Max. Operating Temp:
 Shore Durometer
 Specific Gravity:
 Ult. Elongation %:
 Brittle Temp:
 Tensile Strength PSI:
 Dielectric Strength, v./ml
 U.L. Rating:
 MEETS:

1101650109
 BLUE PVC
 05-916R
 105 C
 "A" 65
 1.27
 325

 1500 PSI

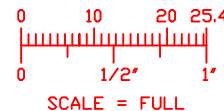

		VTE Incorporated 5437 Robinson Road, P.O. Box 790 Pellston, Michigan 49769 Telephone: 1-800-527-9256, 231-539-8000 FAX: 231-539-0914	
		REF:	DATE:
	4-8-98	CHK'D BY:	.012 LBS. / 5.49 G.
TITLE: ALTERNATOR BOOT			
MATERIAL:		PART NO.	
		800N5V09	
COLOR:	DRG CLASS		