

PROPRIETARY RIGHTS ARE CLAIMED FOR THE MATERIAL DISCLOSED IN THIS DRAWING.

TYP. WALL THICKNESS = 1.5

LTR.	REVISIONS	DATE
⌒	MATERIAL NOTES REVISED	07-MAY-02
B	REVISED TO AGREE WITH PARTS AS MFG.	04-APR-03

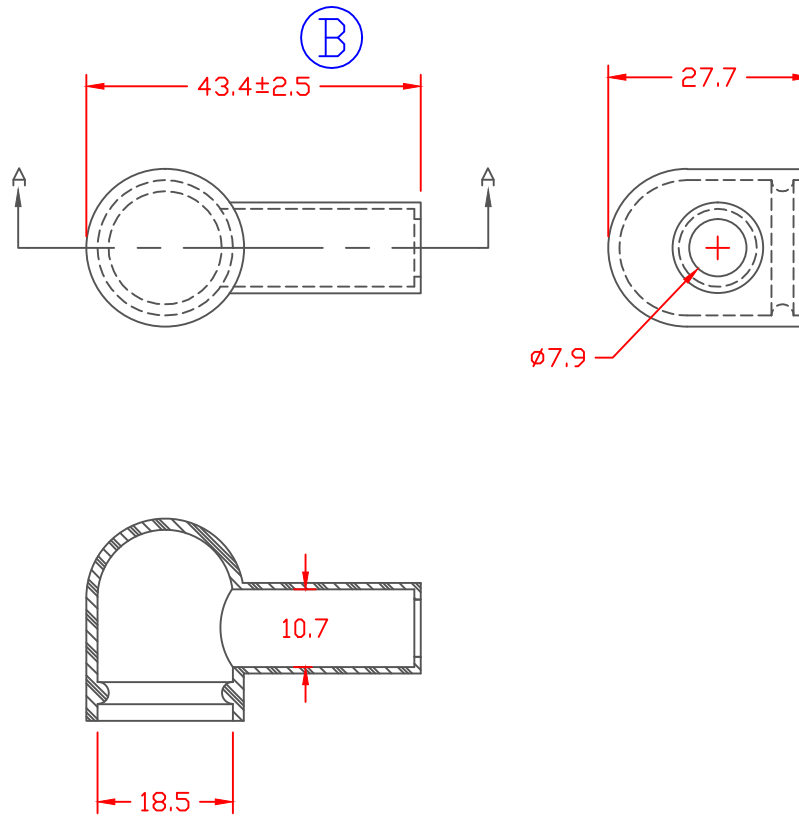

SECTION A-A

TOLERANCE UNLESS OTHERWISE SPECIFIED: ±0.30"/±0.8mm  
 RADIAL DIAMETERS TO BE MEASURED OVER MANDRELS,  
 RING GAGES OR PIN GAGES OF SUITABLE SIZE

VTE Material Part No:	1101700102
Material:	RED PVC
Material Part No	M1170 FR RD or Equivalent
Max. Operating Temp:	105 C
Shore Durometer	"A" 15 SEC. 70+/-5
Specific Gravity:	1.34
Ult. Elongation %:	275 Minimum
Tensile Strength PSI:	1600 PSI Minimum
U.L. Rating:	94 V0

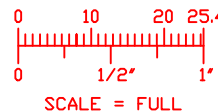

		<b>VTE Incorporated</b> 5437 Robinson Road, P.O. Box 790 Pellston, Michigan 49769 Telephone: 1-800-527-9256, 231-539-8000 FAX: 231-539-0914	
		REF:	DATE:
	4-8-98	CHK'D BY:	.011 LBS. / 4.98 G.
TITLE: ALTERNATOR BOOT			
MATERIAL:		PART NO.	
		800N8F02	
COLOR:	DRG CLASS		