

PROPRIETARY RIGHTS ARE CLAIMED FOR THE MATERIAL DISCLOSED IN THIS DRAWING.

TYP. WALL THICKNESS = 1.5

LTR.	REVISIONS	DATE
⌒	MATERIAL NOTES REVISED	07-MAY-02
B	REVISED TO AGREE WITH PARTS AS MFG.	04-APR-03

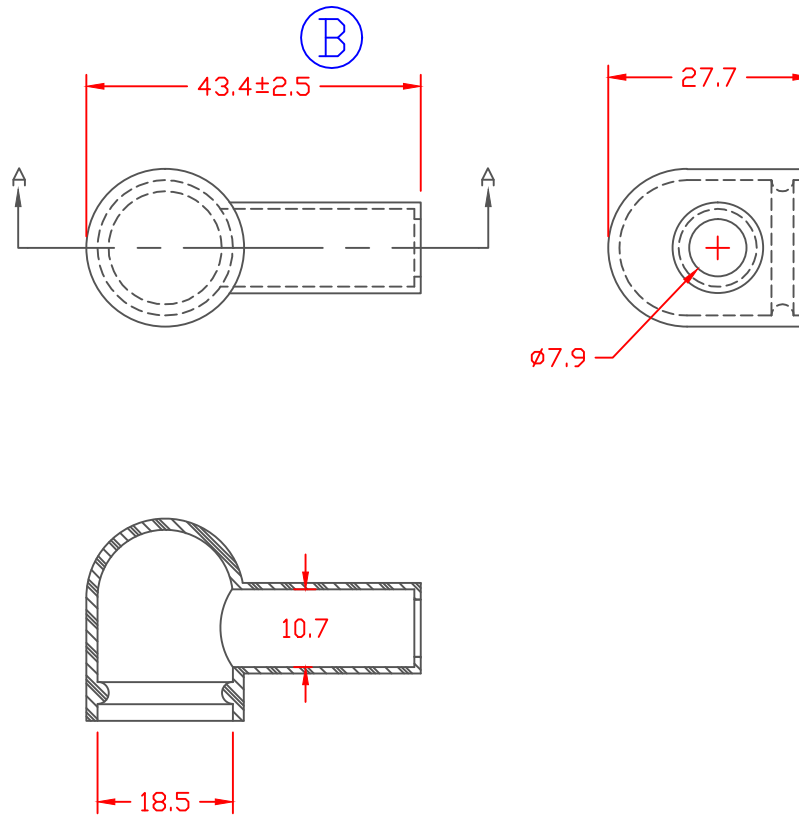

SECTION A-A

TOLERANCE UNLESS OTHERWISE SPECIFIED: ±0.30"/±0.8mm  
 RADIAL DIAMETERS TO BE MEASURED OVER MANDRELS,  
 RING GAGES OR PIN GAGES OF SUITABLE SIZE

VTE Material Part No:  
 Material:  
 Material Part No  
 Max. Operating Temp:  
 Shore Durometer  
 Specific Gravity:  
 Ult. Elongation %:  
 Tensile Strength PSI:  
 U.L. Rating:

1101700114  
 BLACK PVC  
 M1170-FR or Equivalent  
 105 C  
 "A" 15 SEC. 70+/-5  
 1.34  
 275 Minimum  
 1600 PSI Minimum  
 94 V0



		<b>VTE Incorporated</b> 5437 Robinson Road, P.O. Box 790 Pellston, Michigan 49769 Telephone: 1-800-527-9256, 231-539-8000 FAX: 231-539-0914	
		REF:	DATE: 4-8-98
TITLE: <b>ALTERNATOR BOOT</b>			
MATERIAL:		PART NO. <b>800N8F14</b>	
COLOR:	DRG CLASS		