

PROPRIETARY RIGHTS ARE CLAIMED FOR THE MATERIAL DISCLOSED IN THIS DRAWING.

TYP. WALL THICKNESS = 1.5

LTR.	REVISIONS	DATE
≠	*****	00-00-98

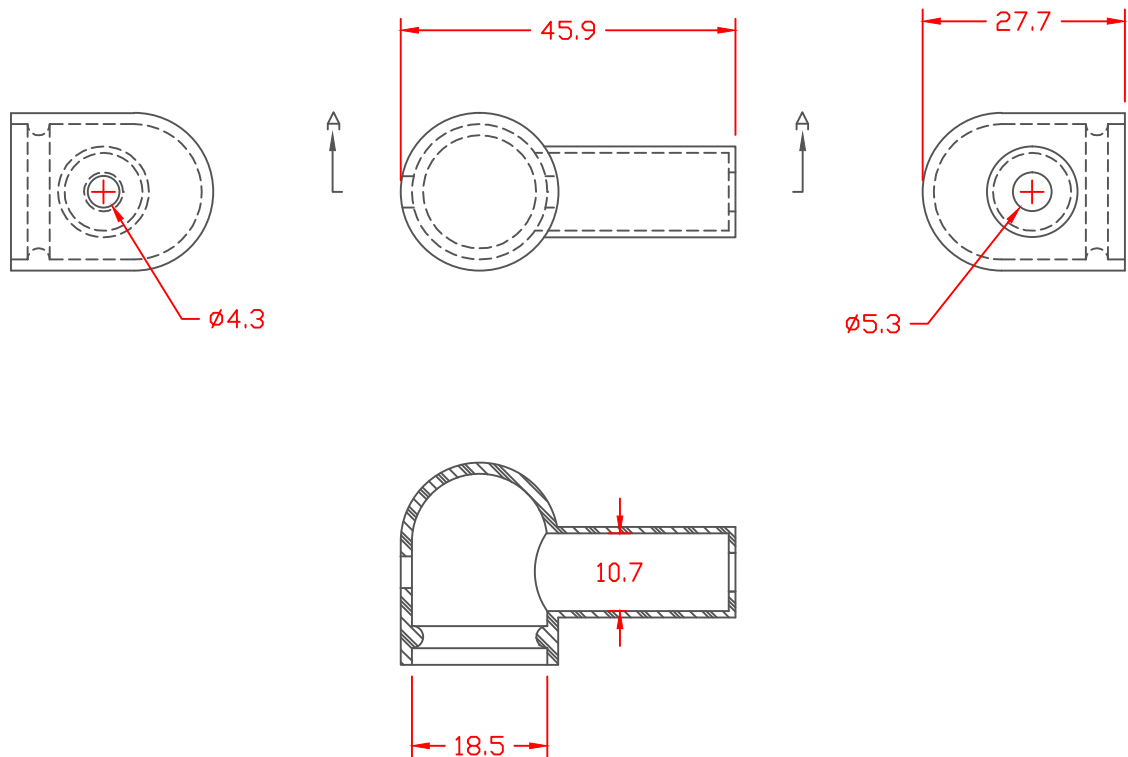

SECTION A-A

TOLERANCE UNLESS OTHERWISE SPECIFIED: ±.030"/±0.8mm
 RADIAL DIAMETERS TO BE MEASURED OVER MANDRELS,
 RING GAGES OR PIN GAGES OF SUITABLE SIZE

VTE Material Part No:	1101700114
Material:	BLACK PVC
Material Part No	M1170-FR or Equivalent
Max. Operating Temp:	105 C
Shore Durometer	"A" 15 SEC. 70+/-5
Specific Gravity:	1.34
Ult. Elongation %:	275 Minimum
Tensile Strength PSI:	1600 PSI Minimum
U.L. Rating:	94 V0

	VTE Incorporated 5437 Robinson Road, P.O. Box 790 Pellston, Michigan 49769 Telephone: 1-800-527-9256, 231-539-8000 FAX: 231-539-0914	
---	---	--

REF:	DATE: 4-8-98	DRN BY: JC CHK'D BY:	WEIGHT: 4 grams
TITLE: ALTERNATOR BOOT			
MATERIAL:		PART NO. 800X5F14	
COLOR:	DRG CLASS		

