

PROPRIETARY RIGHTS ARE CLAIMED FOR THE MATERIAL DISCLOSED IN THIS DRAWING.

TYP. WALL THICKNESS = 1.5

LTR.	REVISIONS	DATE
≡	*****	00-00-98

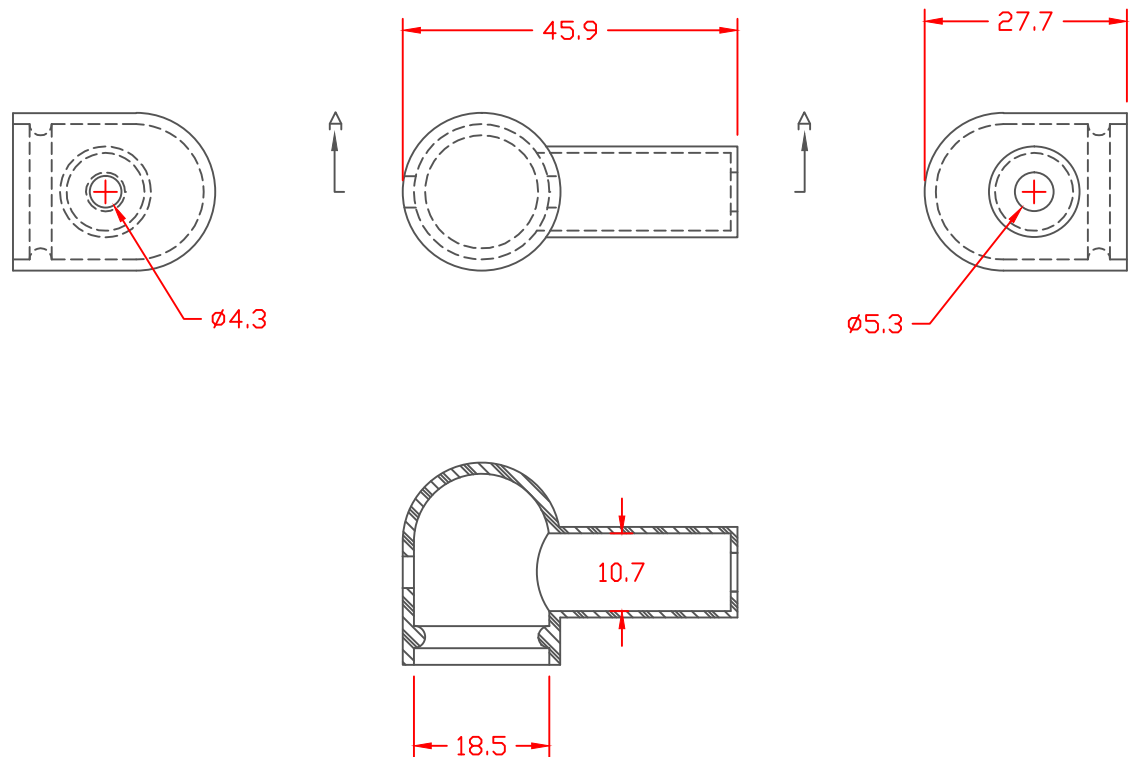

SECTION A-A

TOLERANCE UNLESS OTHERWISE SPECIFIED: ±.030"/±0.8mm
 RADIAL DIAMETERS TO BE MEASURED OVER MANDRELS,
 RING GAGES OR PIN GAGES OF SUITABLE SIZE

VTE Material Part No: 1101650102
 Material: RED PVC
 Material Part No: 9812-65-RED683
 Max. Operating Temp: 105 C
 Shore Durometer "A" 10 SEC. 67/62
 Specific Gravity: 1.34
 Ult. Elongation %: 475
 Brittle Temp: -44 C
 Tensile Strength PSI: 1547 PSI

U.L. Rating: 94 V2
 MEETS: FMVSS.302



		VTE Incorporated 5437 Robinson Road, P.O. Box 790 Pellston, Michigan 49769 Telephone: 1-800-527-9256, 231-539-8000 FAX: 231-539-0914	
		REF:	DATE: 4-8-98
TITLE: ALTERNATOR BOOT		CHK'D BY:	
MATERIAL:		PART NO. 800X5V02	
COLOR:	DRG CLASS		