

PROPRIETARY RIGHTS ARE CLAIMED FOR THE MATERIAL DISCLOSED IN THIS DRAWING.

TYP. WALL THICKNESS = 1.5

LTR.	REVISIONS	DATE
≡	*****	00-00-98

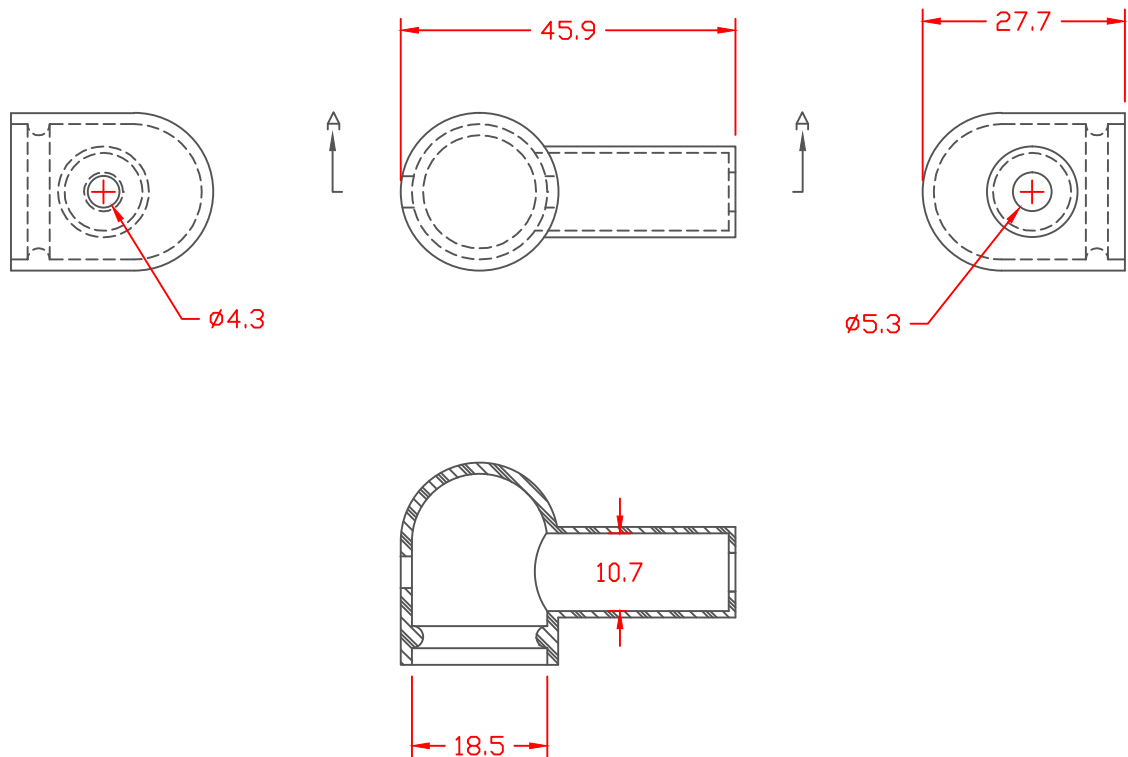

SECTION A-A

TOLERANCE UNLESS OTHERWISE SPECIFIED: ± 0.30 / ± 0.8 mm
 RADIAL DIAMETERS TO BE MEASURED OVER MANDRELS,
 RING GAGES OR PIN GAGES OF SUITABLE SIZE

VTE Material Part No:	1101650109
Material:	BLUE PVC
Material Part No	05-916R
Max. Operating Temp:	105 C
Shore Durometer	"A" 65
Specific Gravity:	1.27
Ult. Elongation %:	325
Brittle Temp:	****
Tensile Strength PSI:	1500 PSI
Dielectric Strength, v./ml	****
U.L. Rating:	****
MEETS:	****



		VTE Incorporated 5437 Robinson Road, P.O. Box 790 Pellston, Michigan 49769 Telephone: 1-800-527-9256, 231-539-8000 FAX: 231-539-0914	
		REF:	DATE:
	4-8-98	CHK'D BY:	4 grams
TITLE: ALTERNATOR BOOT			
MATERIAL:		PART NO.	
COLOR:		800X5V09	
DRG CLASS			