

PROPRIETARY RIGHTS ARE CLAIMED FOR THE MATERIAL DISCLOSED IN THIS DRAWING.

TYP. WALL THICKNESS = 1.5

| | | |
|------|-----------|----------|
| LTR. | REVISIONS | DATE |
| ≡ | ***** | 00-00-98 |

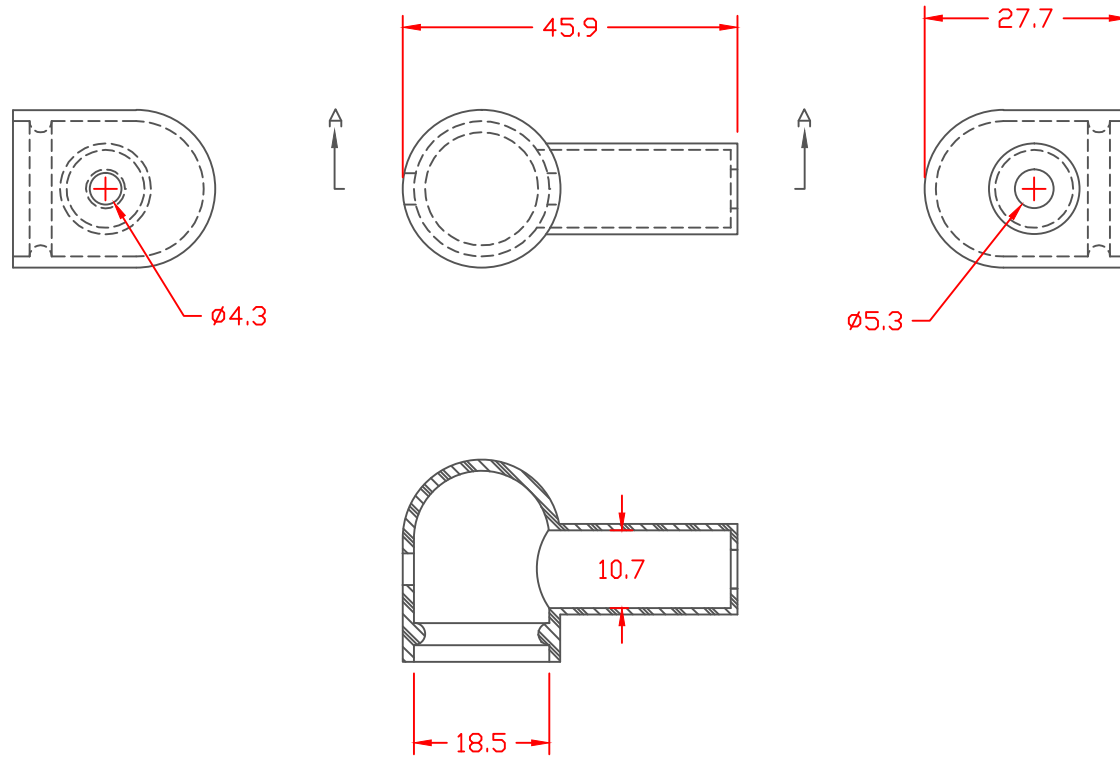

SECTION A-A

TOLERANCE UNLESS OTHERWISE SPECIFIED: ±.030"/±0.8mm
 RADIAL DIAMETERS TO BE MEASURED OVER MANDRELS,
 RING GAGES OR PIN GAGES OF SUITABLE SIZE

| | |
|-----------------------|-------------------|
| VTE Material Part No: | 1101650114 |
| Material: | BLACK PVC |
| Material Part No: | 9812-65 |
| Max. Operating Temp: | 105 C |
| Shore Durometer: | "A" 10 SEC. 67/63 |
| Specific Gravity: | 1.33 |
| Ult. Elongation %: | 520 |
| Brittle Temp: | -36 C |
| Tensile Strength PSI: | 1563 PSI |
| U.L. Rating: | 94 V2 |
| MEETS: | FMVSS.302 |

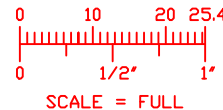

| | | | |
|---|-----------|---|---------|
|  | | VTE Incorporated 5437 Robinson Road, P.O. Box 790 Pellston, Michigan 49769 Telephone: 1-800-527-9256, 231-539-8000 FAX: 231-539-0914 | |
| | | REF: | DATE: |
| | 4-8-98 | CHK'D BY: | 4 grams |
| TITLE: ALTERNATOR BOOT | | | |
| MATERIAL: | | PART NO. | |
| | | 800X5V14 | |
| COLOR: | DRG CLASS | | |