

PROPRIETARY RIGHTS ARE CLAIMED FOR THE MATERIAL DISCLOSED IN THIS DRAWING.

TYP. WALL THICKNESS = 1.5

LTR.	REVISIONS	DATE
⌒	MATERIAL NOTES REVISED	07-MAY-02
B	REVISED TO AGREE WITH PARTS AS MFG.	04-APR-03

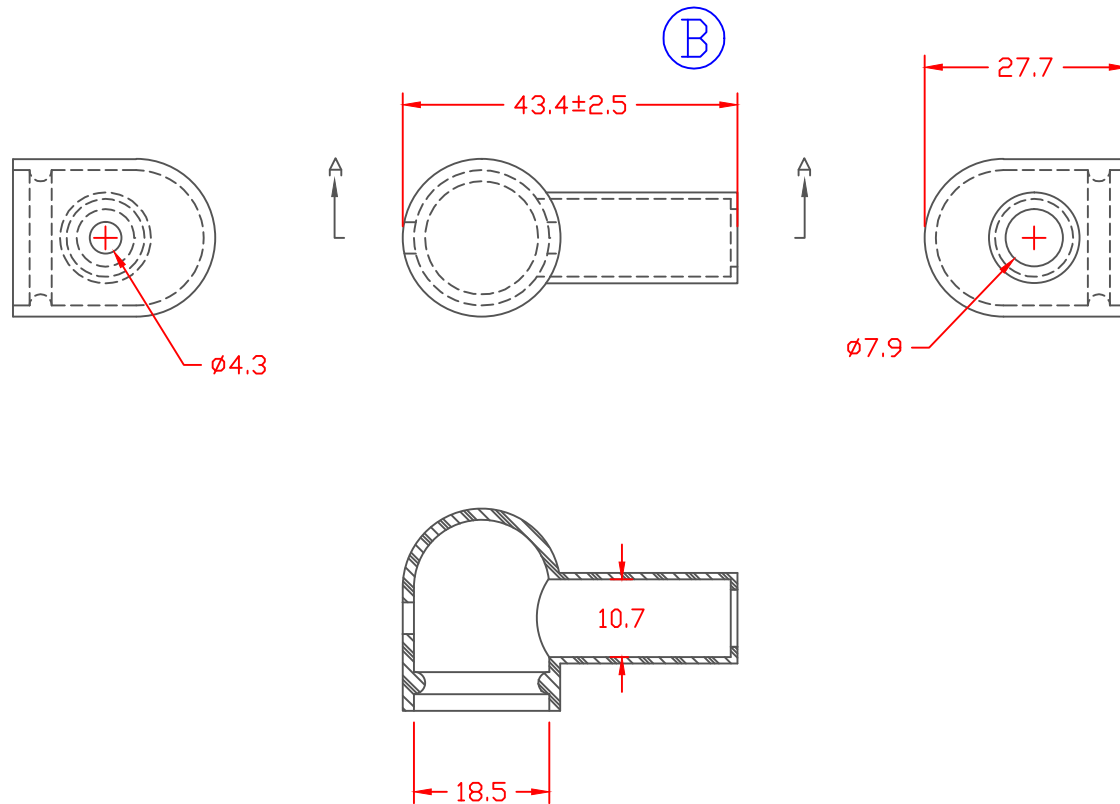

SECTION A-A

TOLERANCE UNLESS OTHERWISE SPECIFIED: ±.030"/±0.8mm
 RADIAL DIAMETERS TO BE MEASURED OVER MANDRELS,
 RING GAGES OR PIN GAGES OF SUITABLE SIZE

VTE Material Part No:
 Material:
 Material Part No
 Max. Operating Temp:
 Shore Durometer
 Specific Gravity:
 Ult. Elongation %:
 Tensile Strength PSI:
 U.L. Rating:

1101700102
 RED PVC
 M1170 FR RD or Equivalent
 105 C
 "A" 15 SEC. 70+/-5
 1.34
 275 Minimum
 1600 PSI Minimum
 94 V0



		VTE Incorporated 5437 Robinson Road, P.O. Box 790 Pellston, Michigan 49769 Telephone: 1-800-527-9256, 231-539-8000 FAX: 231-539-0914	
		REF:	DATE:
	4-8-98	CHK'D BY:	4 grams
TITLE: ALTERNATOR BOOT			
MATERIAL:		PART NO.	
COLOR:		800X8F02	
DRG CLASS			