

PROPRIETARY RIGHTS ARE CLAIMED FOR THE MATERIAL DISCLOSED IN THIS DRAWING.

TYP. WALL THICKNESS = 1.5

LTR.	REVISIONS	DATE
≠	*****	00-00-98

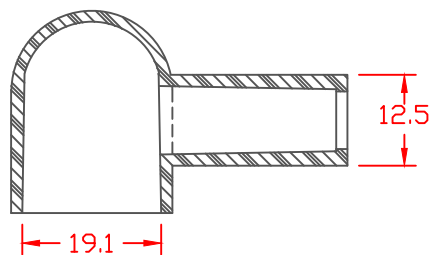
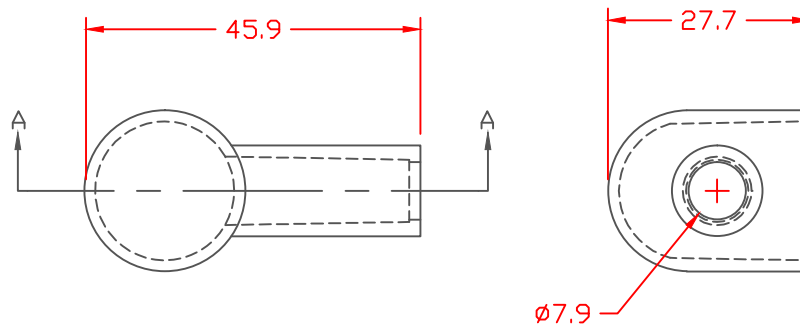

SECTION A-A

TOLERANCE UNLESS OTHERWISE SPECIFIED: ±.030"/±0.8mm  
 RADIAL DIAMETERS TO BE MEASURED OVER MANDRELS,  
 RING GAGES OR PIN GAGES OF SUITABLE SIZE

VTE Material Part No: 1101700102  
 Material: RED PVC  
 Material Part No: M1170 FR RD or Equivalent  
 Max. Operating Temp: 105 C  
 Shore Durometer "A" 15 SEC. 70+/-5  
 Specific Gravity: 1.34  
 Ult. Elongation %: 275 Minimum  
 Tensile Strength PSI: 1600 PSI Minimum  
 U.L. Rating: 94 V0

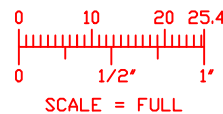

		<b>VTE Incorporated</b> 5437 Robinson Road, P.O. Box 790 Pellston, Michigan 49769 Telephone: 1-800-527-9256, 231-539-8000 FAX: 231-539-0914	
		REF:	DATE:
	4-13-98	CHK'D BY:	012 LBS. / 5.49 G.
TITLE: EYELET TERMINAL BOOT			
MATERIAL:		PART NO.	
		801N8F02	
COLOR:	DRG CLASS		