

PROPRIETARY RIGHTS ARE CLAIMED FOR THE MATERIAL DISCLOSED IN THIS DRAWING.

| LTR. | REVISIONS | DATE |
|------|--|---------|
| A | ADDED MAXIMUM WALL THICKNESS DIMENSION | 20APR06 |
| B | ADDED TOLERANCE NOTE FOR DIA. | 20APR06 |

THIS PRODUCT MEETS THE REQUIRMENTS OF M&G ELECTRONICS PART NUMBER 310105008

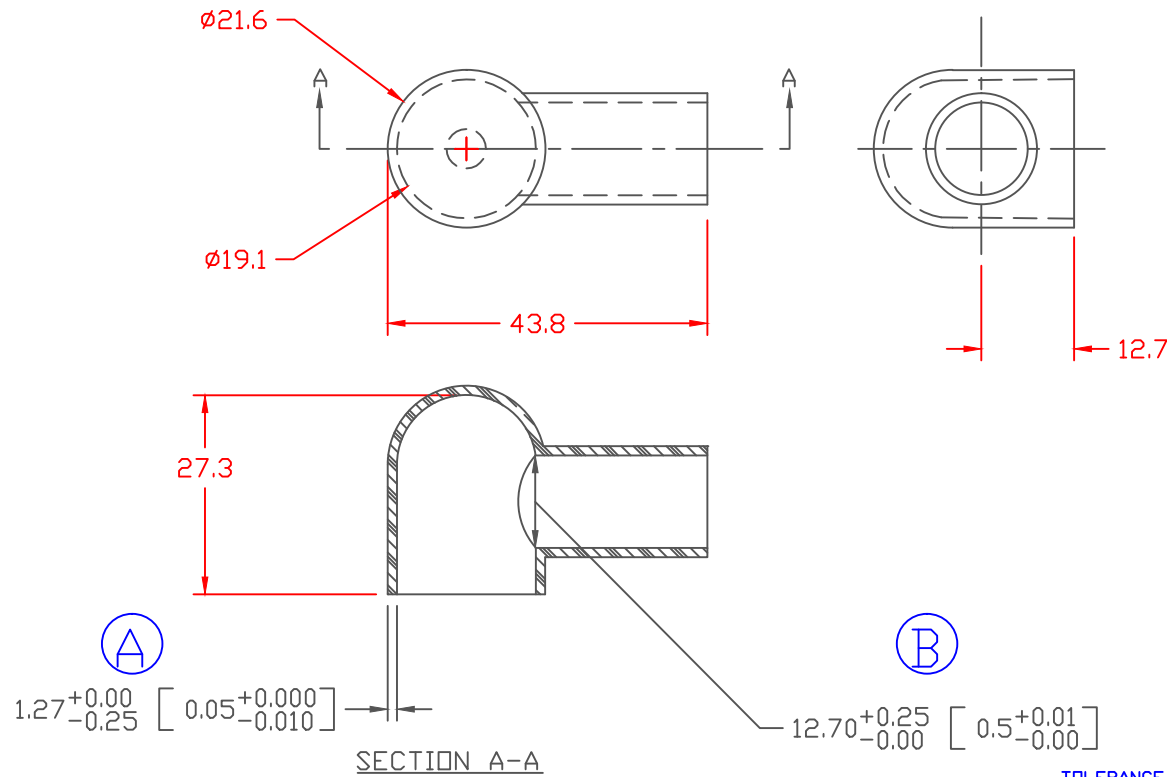

TOLERANCE UNLESS OTHERWISE SPECIFIED: $\pm 0.30^*/\pm 0.8\text{mm}$
 RADIAL DIAMETERS TO BE MEASURED OVER MANDRELS,
 RING GAGES OR PIN GAGES OF SUITABLE SIZE

VTE Material Part No: 1101700102
 Material: RED PVC
 Material Part No: M1170 FR RD or Equivalent
 Max. Operating Temp: 105 C
 Shore Durometer "A" 15 SEC. 70+/-5
 Specific Gravity: 1.34
 Ult. Elongation %: 275 Minimum
 Tensile Strength PSI: 1600 PSI Minimum
 U.L. Rating: 94 V0

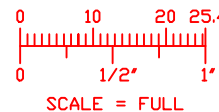

| | | | |
|---|-----------|---|---------------|
|  | | VTE Incorporated 5437 Robinson Road, P.O. Box 790 Pellston, Michigan 49769 Telephone: 1-800-527-9256, 231-539-8000 FAX: 231-539-0914 | |
| | | REF: | DATE: 30SEP03 |
| TITLE: EYELET TERMINAL BOOT | | CHK'D BY: BRH | |
| MATERIAL: AS NOTED | | PART NO. 801N9F02 | |
| COLOR: | DRG CLASS | | |