

PROPRIETARY RIGHTS ARE CLAIMED FOR THE MATERIAL DISCLOSED IN THIS DRAWING.

LTR.	REVISIONS	DATE
A	ADDED MAXIMUM WALL THICKNESS DIMENSION	20APR06
B	ADDED TOLERANCE NOTE FOR DIA.	20APR06

THIS PRODUCT MEETS THE REQUIRMENTS OF M&G ELECTRONICS PART NUMBER 310105008

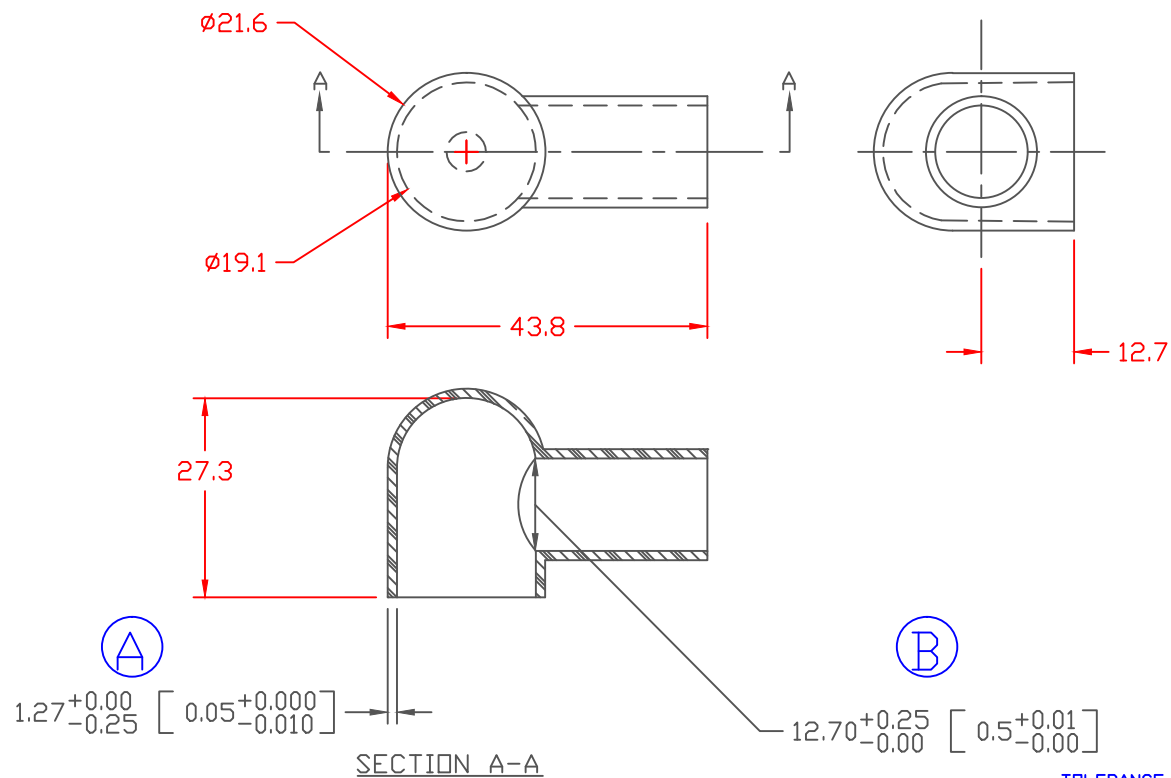

TOLERANCE UNLESS OTHERWISE SPECIFIED: $\pm 0.30^*/\pm 0.8\text{mm}$
 RADIAL DIAMETERS TO BE MEASURED OVER MANDRELS,
 RING GAGES OR PIN GAGES OF SUITABLE SIZE

Material:
Material Part No

Thermoplastic Elastomer
(Santoprene 201-64 or Equivalent)
Durometer 67 to 73 Shore A

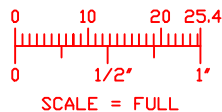

		VTE Incorporated 5437 Robinson Road, P.O. Box 790 Pellston, Michigan 49769 Telephone: 1-800-527-9256, 231-539-8000 FAX: 231-539-0914	
		REF:	DATE:
	30SEP03	LWH	6 grams
TITLE:		EYELET TERMINAL BOOT	
MATERIAL: AS NOTED		PART NO.	
COLOR:		801N9	
DRG CLASS			