

PROPRIETARY RIGHTS ARE CLAIMED FOR THE MATERIAL DISCLOSED IN THIS DRAWING.

LTR.	REVISIONS	DATE
≠	*****	00-00-98

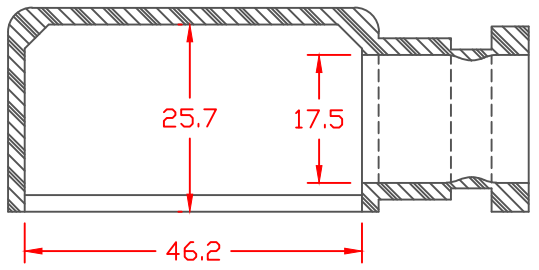
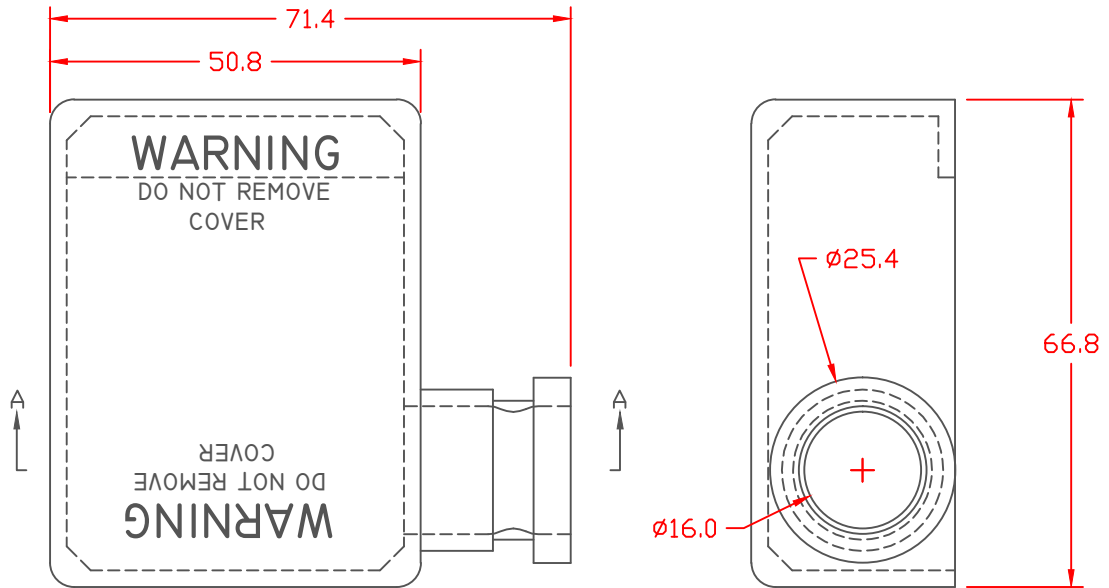

SECTION A-A

TOLERANCE UNLESS OTHERWISE SPECIFIED: ±.030"/±0.8mm  
 RADIAL DIAMETERS TO BE MEASURED OVER MANDRELS,  
 RING GAGES OR PIN GAGES OF SUITABLE SIZE  
 TYP. WALL THICKNESS = 2.3  
 TYP. CHAMFER = 3.3  
 TYP. RADIUS = 3.3

VTE Material Part No:	1101700114
Material:	BLACK PVC
Material Part No	M1170-FR or Equivalent
Max. Operating Temp:	105 C
Shore Durometer	"A" 15 SEC. 70+/-5
Specific Gravity:	1.34
Ult. Elongation %:	275 Minimum
Tensile Strength PSI:	1600 PSI Minimum
U.L. Rating:	94 V0

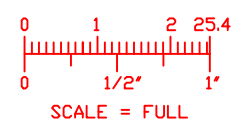

		<b>VTE Incorporated</b> 5437 Robinson Road, P.O. Box 790 Pellston, Michigan 49769 Telephone: 1-800-527-9256, 231-539-8000 FAX: 231-539-0914	
		REF:	DATE: 4-14-98
TITLE: BATTERY TERMINAL BOOT WITH GROOVE			
MATERIAL:		PART NO. RIGHT HAND	
COLOR:		900R9F14	
DRG CLASS			