

THE INFORMATION CONTAINED IN THIS DRAWING IS THE SOLE PROPERTY OF VTE INCORPORATED. ANY REPRODUCTION IN PART OR WHOLE WITHOUT THE WRITTEN PERMISSION OF VTE INCORPORATED IS PROHIBITED.

LTR.	REVISIONS	DATE
✂	*****	00-00-98

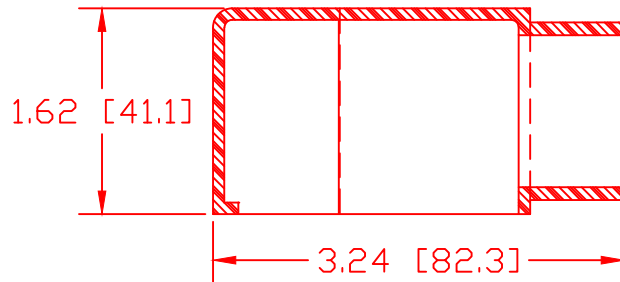
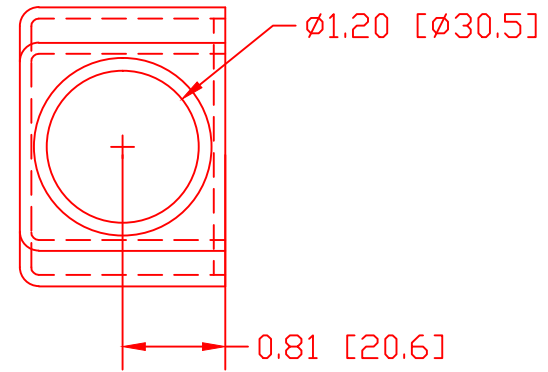
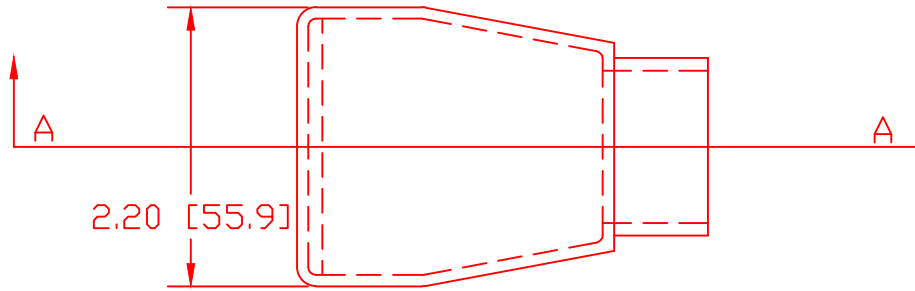

TOLERANCE UNLESS OTHERWISE SPECIFIED:  $\pm 0.030"/\pm 0.8\text{mm}$   
 RADIAL DIAMETERS TO BE MEASURED OVER MANDRELS,  
 RING GAGES OR PIN GAGES OF SUITABLE SIZE

VTE Material Part No: 1101650102  
 Material: RED PVC  
 Material Part No: 9812-65-RED683  
 Max. Operating Temp: 105 C  
 Shore Durometer "A" 10 SEC. 67/62  
 Specific Gravity: 1.34  
 Ult. Elongation %: 475  
 Brittle Temp: -44 C  
 Tensile Strength PSI: 1547 PSI

U.L. Rating: 94 V2  
 MEETS: FMVSS.302

		<b>VTE Incorporated</b> 5437 Robinson Road, P.O. Box 790 Pellston, Michigan 49769 Telephone: 1-800-527-9256, 231-539-8000 FAX: 231-539-0914	
		REF: 10557073	DATE: 07MAR01
TITLE: BATTERY TERMINAL INSULATOR			SCALE: NOTED
MATERIAL: NOTED		PART NO. 973N8V02	
COLOR: *****	DRG CLASS *****		