

THE INFORMATION CONTAINED IN THIS DRAWING IS THE SOLE PROPERTY OF VTE INCORPORATED. ANY REPRODUCTION IN PART OR WHOLE WITHOUT THE WRITTEN PERMISSION OF VTE INCORPORATED IS PROHIBITED.

LTR.	REVISIONS	DATE
✂	*****	00-00-98

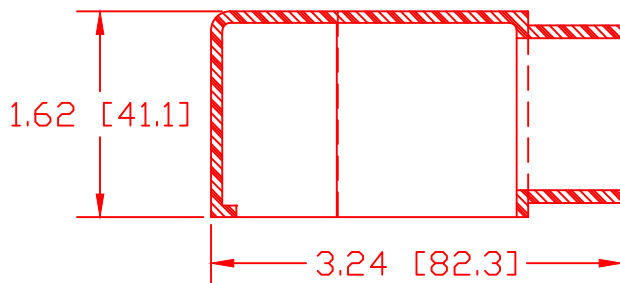
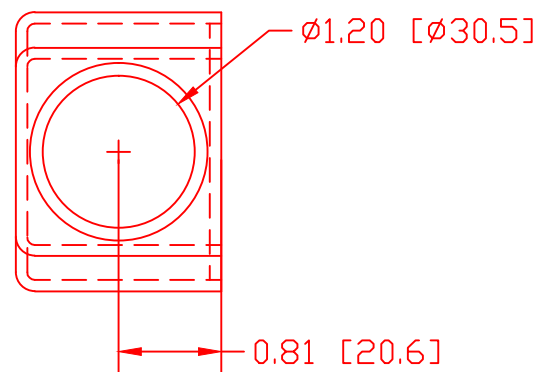
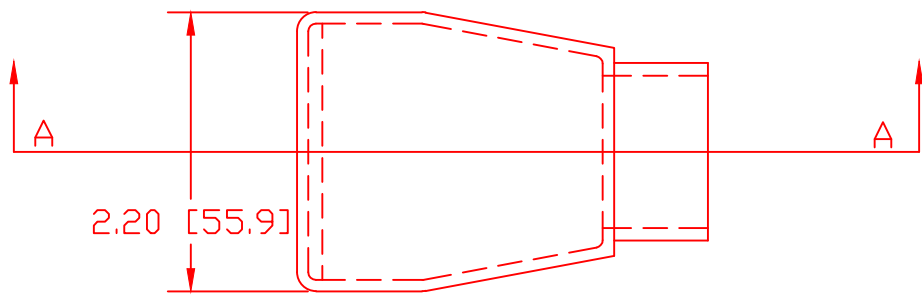

TOLERANCE UNLESS OTHERWISE SPECIFIED:  $\pm 0.030"/\pm 0.8\text{mm}$   
 RADIAL DIAMETERS TO BE MEASURED OVER MANDRELS,  
 RING GAGES OR PIN GAGES OF SUITABLE SIZE

VTE Material Part No: 1101650114  
 Material: BLACK PVC  
 Material Part No: 9812-65  
 Max. Operating Temp: 105 C  
 Shore Durometer "A" 10 SEC. 67/63  
 Specific Gravity: 1.33  
 Ult. Elongation %: 520  
 Brittle Temp: -36 C  
 Tensile Strength PSI: 1563 PSI

U.L. Rating: 94 V2  
 MEETS: FMVSS.302

		<b>VTE Incorporated</b> 5437 Robinson Road, P.O. Box 790 Pellston, Michigan 49769 Telephone: 1-800-527-9256, 231-539-8000 FAX: 231-539-0914	
		REF: 10557073	DATE: 07MAR01
TITLE: BATTERY TERMINAL INSULATOR			SCALE: NOTED
MATERIAL: NOTED		PART NO. 973N8V14	
COLOR: *****	DRG CLASS *****		