

THE INFORMATION CONTAINED IN THIS DRAWING IS THE SOLE PROPERTY OF VTE INCORPORATED. ANY REPRODUCTION IN PART OR WHOLE WITHOUT THE WRITTEN PERMISSION OF VTE INCORPORATED IS PROHIBITED.

LTR.	REVISIONS	DATE
✂	*****	00-00-98

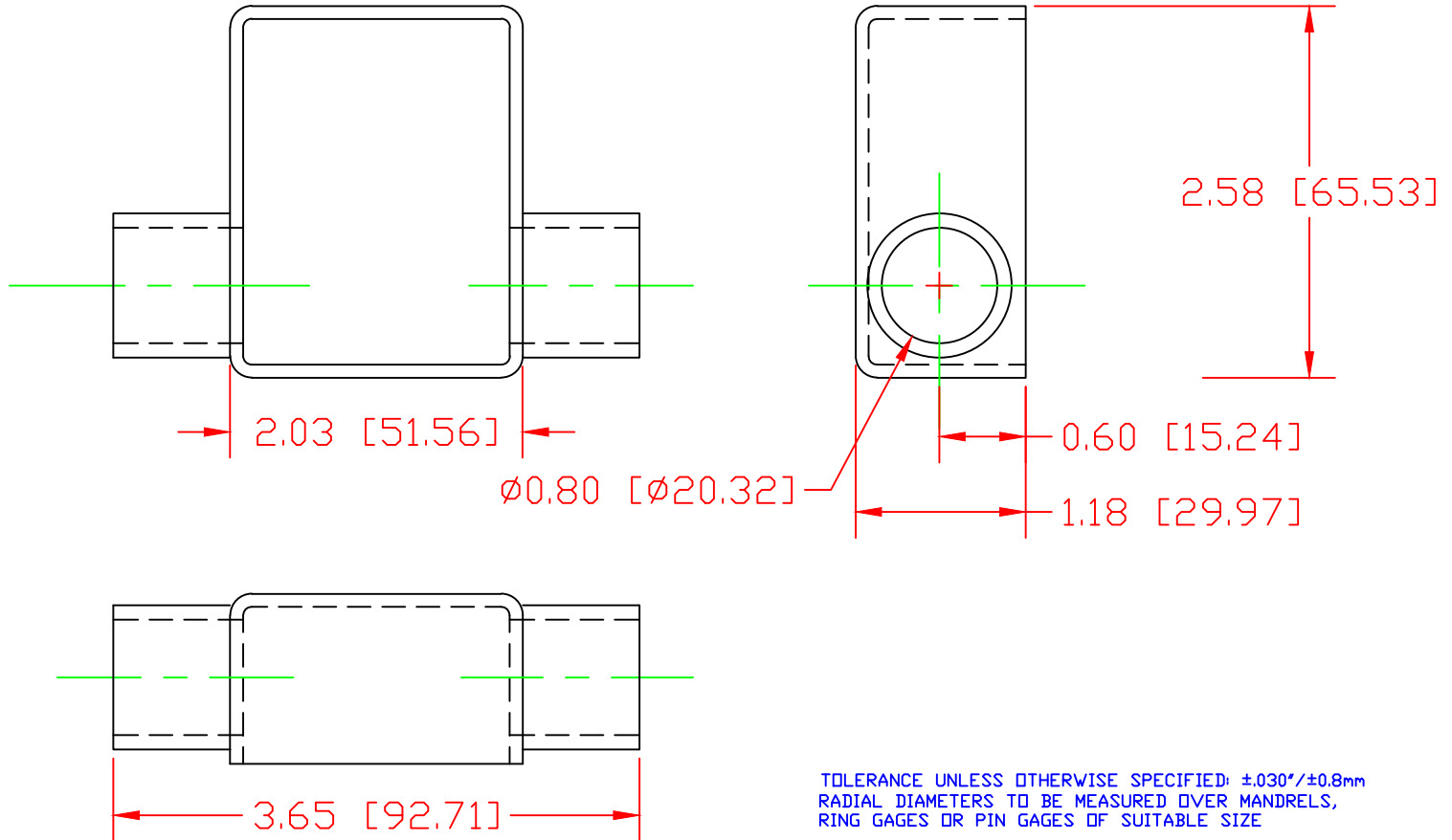

TOLERANCE UNLESS OTHERWISE SPECIFIED: ±.030"/±0.8mm
 RADIAL DIAMETERS TO BE MEASURED OVER MANDRELS,
 RING GAGES OR PIN GAGES OF SUITABLE SIZE

VTE Material Part No: 1101700102
 Material: RED PVC
 Material Part No: M1170 FR RD or Equivalent
 Max. Operating Temp: 105 C
 Shore Durometer "A" 15 SEC. 70+/-5
 Specific Gravity: 1.34
 Ult. Elongation %: 275 Minimum
 Tensile Strength PSI: 1600 PSI Minimum
 U.L. Rating: 94 V0



		VTE Incorporated 5437 Robinson Road, P.O. Box 790 Pellston, Michigan 49769 Telephone: 1-800-527-9256, 231-539-8000 FAX: 231-539-0914	
		REF: 10556475	DATE: 01-JUN-01
TITLE: BATTERY CABLE BOOT			SCALE:
MATERIAL:		PART NO.	
COLOR: *****		975D8F02	
DRG CLASS *****			