

THE INFORMATION CONTAINED IN THIS DRAWING IS THE SOLE PROPERTY OF VTE INCORPORATED. ANY REPRODUCTION IN PART OR WHOLE WITHOUT THE WRITTEN PERMISSION OF VTE INCORPORATED IS PROHIBITED.

LTR.	REVISIONS	DATE
✂	*****	00-00-98

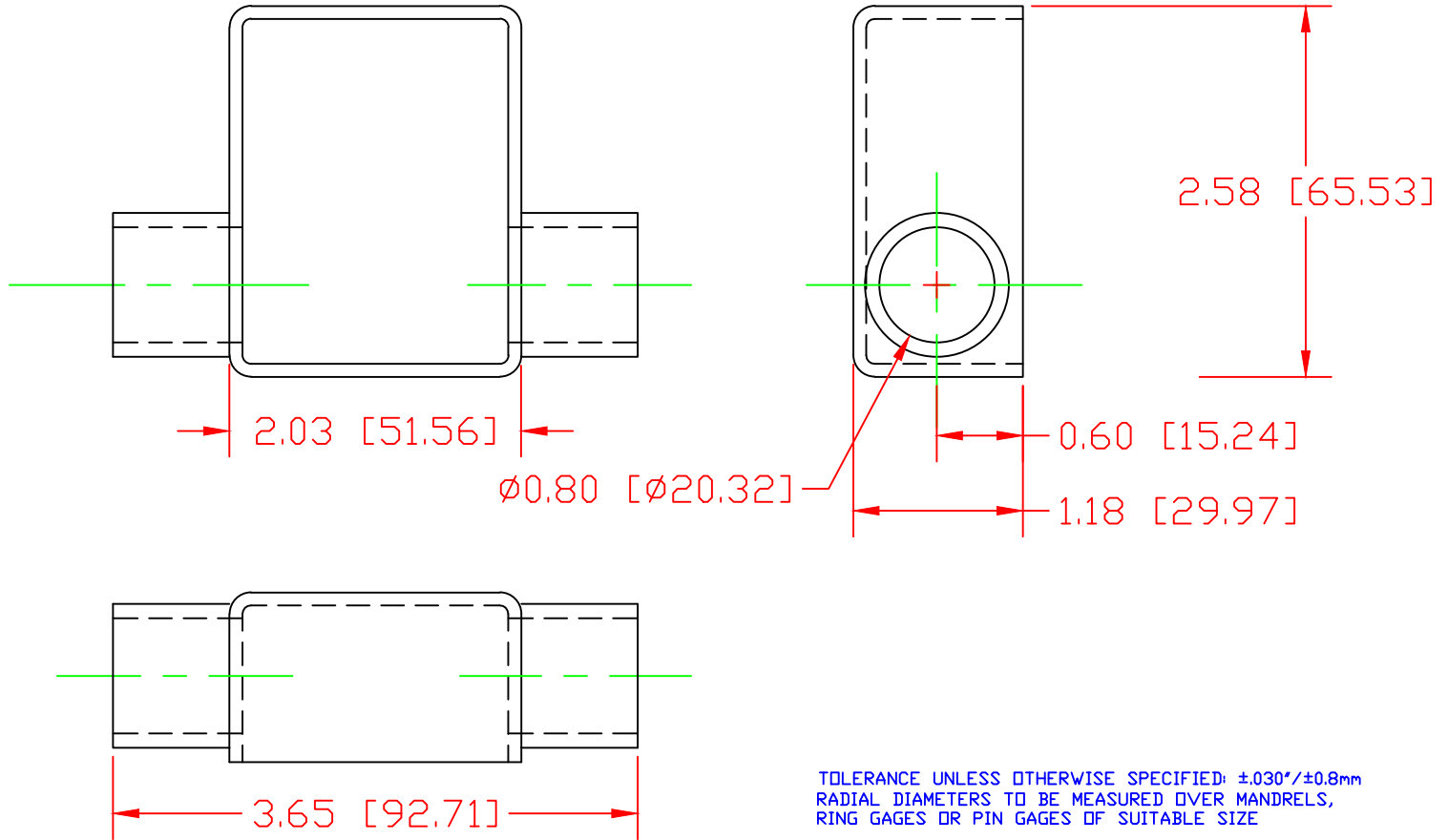

TOLERANCE UNLESS OTHERWISE SPECIFIED: ±.030"/±0.8mm
 RADIAL DIAMETERS TO BE MEASURED OVER MANDRELS,
 RING GAGES OR PIN GAGES OF SUITABLE SIZE

VTE Material Part No: 1101650109
 Material: BLUE PVC
 Material Part No: 05-916R
 Max. Operating Temp: 105 C
 Shore Durometer "A" 65
 Specific Gravity: 1.27
 Ult. Elongation %: 325
 Brittle Temp: *****
 Tensile Strength PSI: 1500 PSI
 Dielectric Strength, v./ml: *****
 U.L. Rating: *****
 MEETS: *****

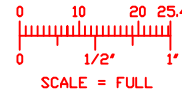

		VTE Incorporated 5437 Robinson Road, P.O. Box 790 Pellston, Michigan 49769 Telephone: 1-800-527-9256, 231-539-8000 FAX: 231-539-0914	
		REF: 10556475	DATE: 01-JUN-01
TITLE: BATTERY CABLE BOOT			SCALE:
MATERIAL:		PART NO.	
COLOR: *****		975D8V09	
DRG CLASS *****			