

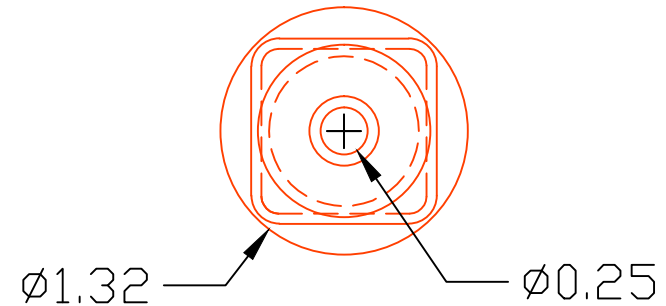

THE INFORMATION CONTAINED IN THIS DRAWING IS THE SOLE PROPERTY OF VTE INCORPORATED. ANY REPRODUCTION IN PART OR WHOLE WITHOUT THE WRITTEN PERMISSION OF VTE INCORPORATED IS PROHIBITED.

LTR.	REVISIONS	DATE
✂	*****	00-000-00

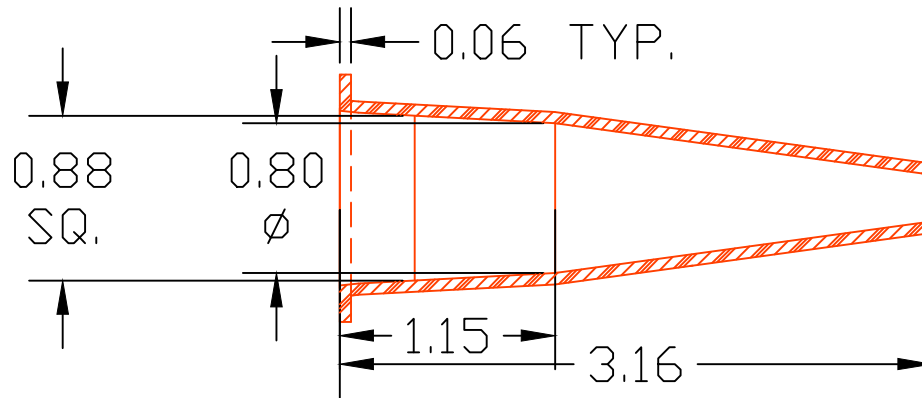
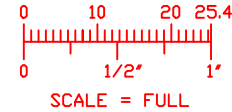

TOLERANCE UNLESS OTHERWISE SPECIFIED:
 MOLDED PRODUCTS ONLY: $\pm 0.30^\circ / \pm 0.8\text{mm}$
 HARDWARE ITEMS: $\pm 0.010^\circ / \pm 0.25\text{mm}$
 RADIAL DIAMETERS TO BE MEASURED OVER MANDRELS,
 RING GAGES OR PIN GAGES OF SUITABLE SIZE

VTE Material Part No:	1101700114
Material:	BLACK PVC
Material Part No	M1170-FR or Equivalent
Max. Operating Temp:	105 C
Shore Durometer	"A" 15 SEC. 70+/-5
Specific Gravity:	1.34
Ult. Elongation %:	275 Minimum
Tensile Strength PSI:	1600 PSI Minimum
U.L. Rating:	94 V0

		VTE Incorporated 5437 Robinson Road, P.O. Box 790 Pellston, Michigan 49769 Telephone: 1-800-527-9256, 231-539-8000 FAX: 231-539-0914	
		REF: *****	DATE: 12JUL07
TITLE: BATTERY TERMINAL INSULATOR			SCALE:
MATERIAL:		PART NO.	
COLOR: *****	DRG CLASS *****	982N9F14	