

THE INFORMATION CONTAINED IN THIS DRAWING IS THE SOLE PROPERTY OF VTE INCORPORATED. ANY REPRODUCTION IN PART OR WHOLE WITHOUT THE WRITTEN PERMISSION OF VTE INCORPORATED IS PROHIBITED.

| LTR. | REVISIONS | DATE |
|------|-----------|-----------|
| ✂ | ***** | 00-000-00 |

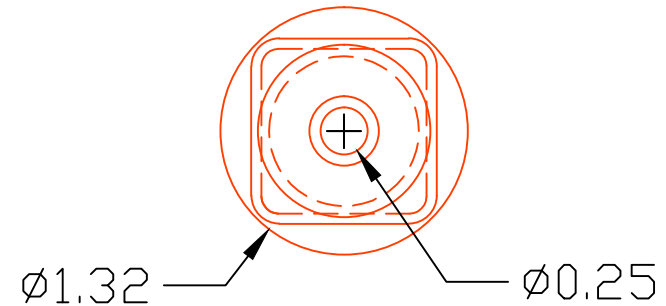
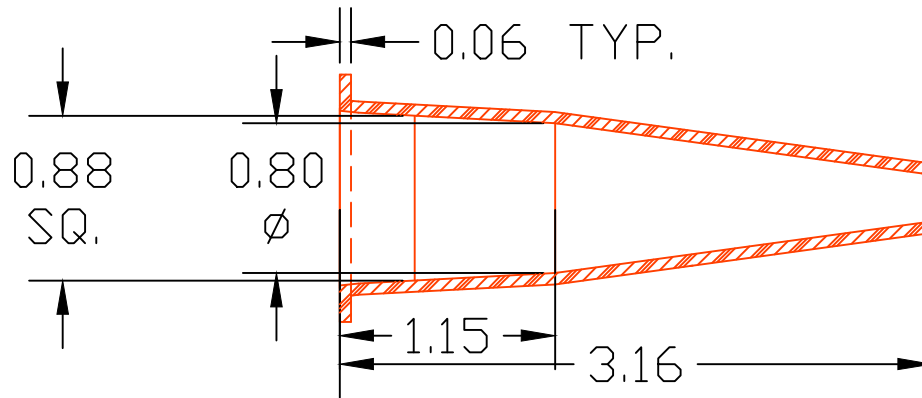
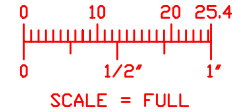

TOLERANCE UNLESS OTHERWISE SPECIFIED:
 MOLDED PRODUCTS ONLY: ±0.30"/±0.8mm
 HARDWARE ITEMS: ±0.010"/±0.25mm
 RADIAL DIAMETERS TO BE MEASURED OVER MANDRELS,
 RING GAGES OR PIN GAGES OF SUITABLE SIZE

VTE Material Part No: 1101650102
 Material: RED PVC
 Material Part No: 9812-65-RED683
 Max. Operating Temp: 105 C
 Shore Durometer: "A" 10 SEC. 67/62
 Specific Gravity: 1.34
 Ult. Elongation %: 475
 Brittle Temp: -44 C
 Tensile Strength PSI: 1547 PSI

U.L. Rating: 94 V2
 MEETS: FMVSS.302

| | | | |
|-----------------------------------|-----------------|---|---------------|
| | | VTE Incorporated 5437 Robinson Road, P.O. Box 790 Pellston, Michigan 49769 Telephone: 1-800-527-9256, 231-539-8000 FAX: 231-539-0914 | |
| | | REF: ***** | DATE: 12JUL07 |
| TITLE: BATTERY TERMINAL INSULATOR | | | SCALE: |
| MATERIAL: | | PART NO. | |
| COLOR: ***** | DRG CLASS ***** | 982N9 V02 | |