

THE INFORMATION CONTAINED IN THIS DRAWING IS THE SOLE PROPERTY OF VTE INCORPORATED. ANY REPRODUCTION IN PART OR WHOLE WITHOUT THE WRITTEN PERMISSION OF VTE INCORPORATED IS PROHIBITED.

LTR.	REVISIONS	DATE
≠	*****	00-000-00

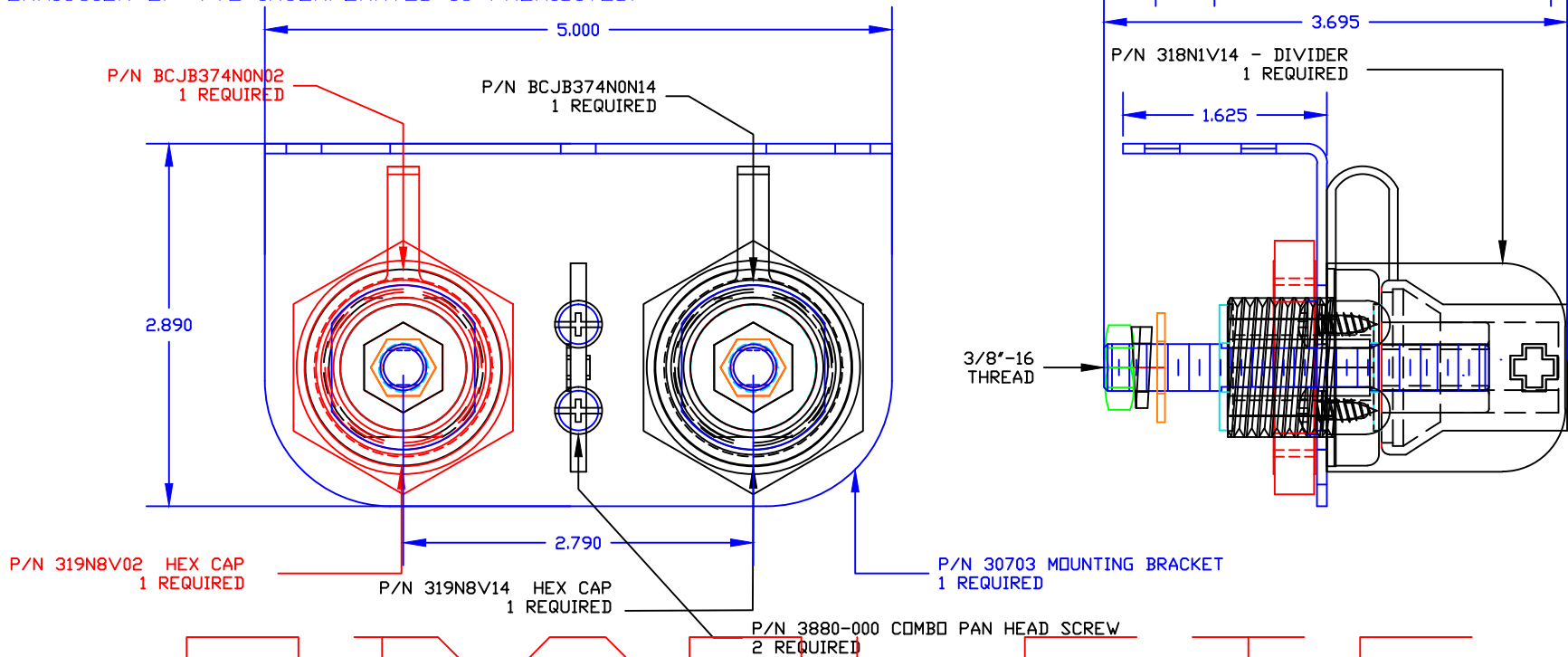

O B S O L E T E

TOLERANCE UNLESS OTHERWISE SPECIFIED:  
 MOLDED PRODUCTS ONLY: ±.030"/±0.8mm  
 HARDWARE ITEMS: ±.010"/±0.25mm  
 RADIAL DIAMETERS TO BE MEASURED OVER MANDRELS,  
 RING GAGES OR PIN GAGES OF SUITABLE SIZE

INCLUDES: (1) BCJB374N0N02

MAXIMUM FASTENER TORQUES: (1) BCJB374N0N14

JAM NUTS: 15 FT./LBS. (180 IN./LBS.)

SEALING NUT: 10 FT./LBS. (120 IN./LBS.)

RECOMMENDED MAXIMUM AMPERAGE: 350 AMPS @ 12VDC



VTE Incorporated

5437 Robinson Road, P.O. Box 790  
 Pellston, Michigan 49769  
 Telephone: 1-800-527-9256, 231-539-8000  
 FAX: 231-539-0914

REF: *****	DATE: 02OCT09	DRN BY: BRH	WEIGHT: *****
TITLE: BRASS CORE JUMPER BUSHING BRACKET MOUNT KIT		CHK'D BY: BRH	SCALE:
MATERIAL:		PART NO.	
COLOR: *****	DRG CLASS *****	BCJB374BMK	