

THE INFORMATION CONTAINED IN THIS DRAWING IS THE SOLE PROPERTY OF VTE INCORPORATED. ANY REPRODUCTION IN PART OR WHOLE WITHOUT THE WRITTEN PERMISSION OF VTE INCORPORATED IS PROHIBITED.

| LTR. | REVISIONS | DATE      |
|------|-----------|-----------|
| ≠    | *****     | 00-000-00 |

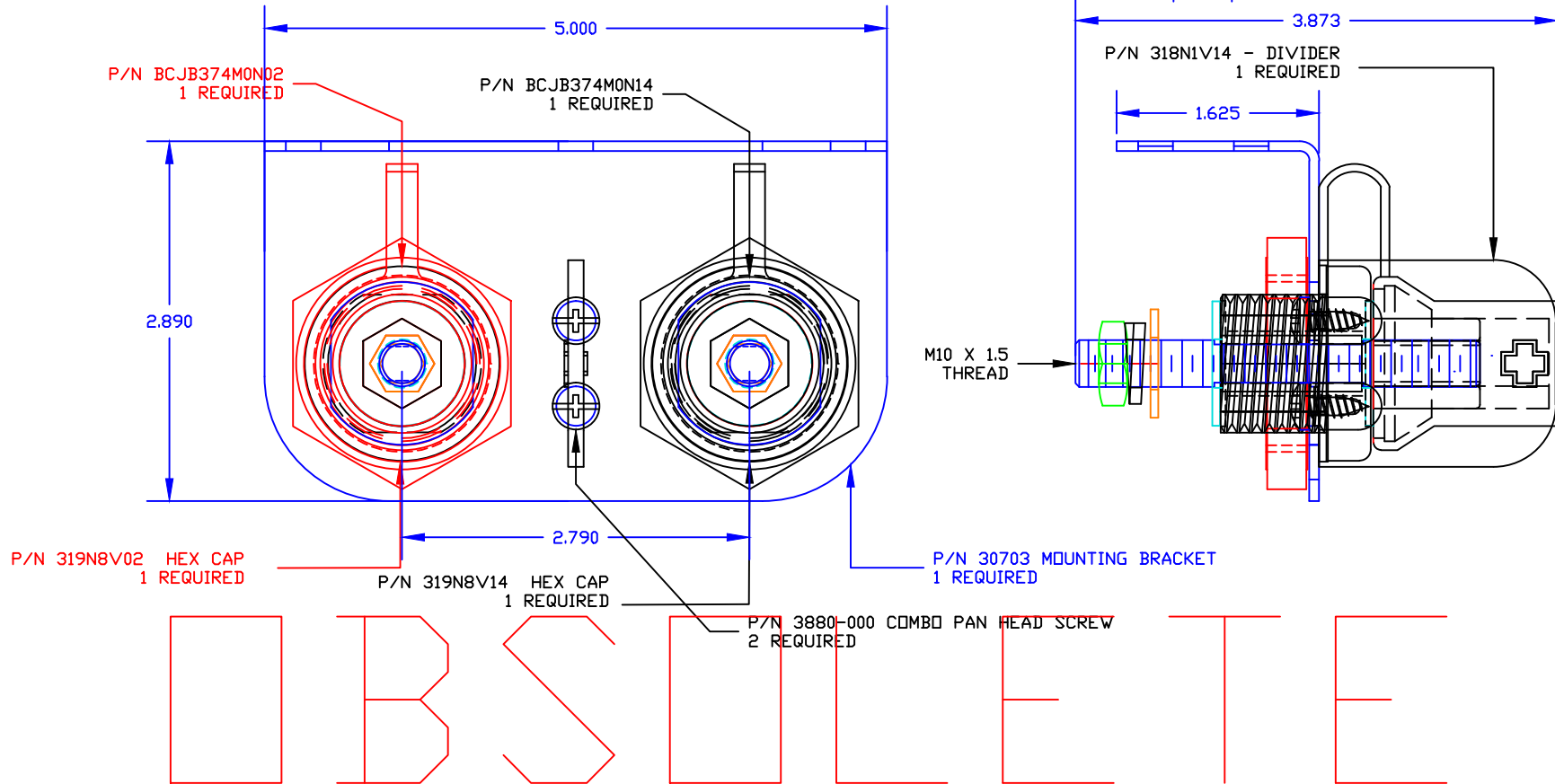

INCLUDES: (1) BCJB374M0N02

MAXIMUM FASTENER TORQUES: (1) BCJB374M0N14

JAM NUTS: 15 FT./LBS. (180 IN./LBS.)

SEALING NUT: 10 FT./LBS. (120 IN./LBS.)

CURRENT CARRYING CAPACITY: 350 AMPS @ 12VDC

TOLERANCE UNLESS OTHERWISE SPECIFIED:  
 MOLDED PRODUCTS ONLY: ±.030"/±0.8mm  
 HARDWARE ITEMS: ±.010"/±0.25mm  
 RADIAL DIAMETERS TO BE MEASURED OVER MANDRELS,  
 RING GAGES OR PIN GAGES OF SUITABLE SIZE



VTE Incorporated

5437 Robinson Road, P.O. Box 790  
 Pellston, Michigan 49769  
 Telephone: 1-800-527-9256, 231-539-8000  
 FAX: 231-539-0914

|  |               |               |               |
|--|---------------|---------------|---------------|
| REF: *****   | DATE: 02OCT09 | DRN BY: BRH   | WEIGHT: ***** |
|  |               | CHK'D BY: BRH |               |
| TITLE: BRASS CORE JUMPER BUSHING BRACKET MOUNT KIT |               |               | SCALE:        |
| MATERIAL:  |               | PART NO.      |               |
| COLOR: *****                                       |               | BCJB374BMKM   |               |
| DRG CLASS *****                                    |               |               |               |