

THE INFORMATION CONTAINED IN THIS DRAWING IS THE SOLE PROPERTY OF VTE INCORPORATED. ANY REPRODUCTION IN PART OR WHOLE WITHOUT THE WRITTEN PERMISSION OF VTE INCORPORATED IS PROHIBITED.

LTR.	REVISIONS	DATE	INT
△	PN 329NOV** CHANGED TO PN 329NDN**	27JUN16	MDL

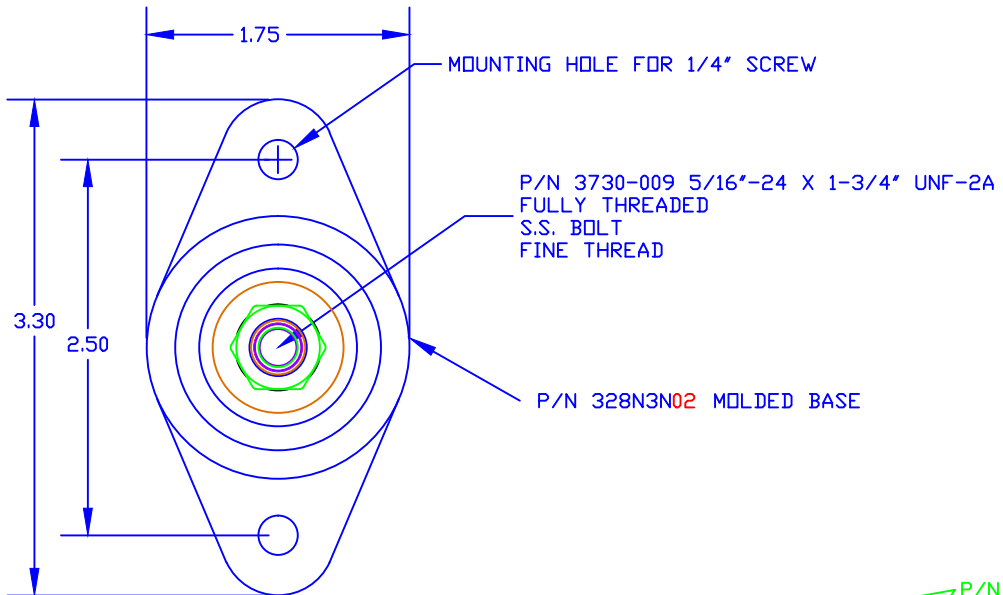

DO NOT SCALE

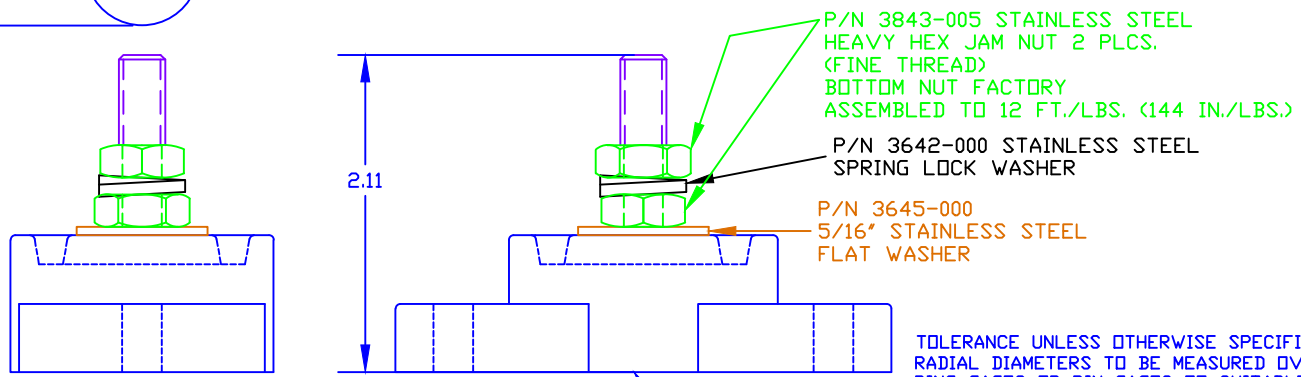

TOLERANCE UNLESS OTHERWISE SPECIFIED: ±0.030"/±0.8mm
 RADIAL DIAMETERS TO BE MEASURED OVER MANDRELS,
 RING GAGES OR PIN GAGES OF SUITABLE SIZE

BASE MATERIAL: GLASS-REINFORCED NYLON
 BASE MATERIAL U.L. RATING: 94 HB
 DIELECTRIC STRENGTH: 630 VOLTS/MIL PER ASTM D149
 CURRENT RATING: 160 AMPS
 TEMP. RISE AT LOAD: 52 DEG. F.
 BREAKOUT TORQUE: 22 FT./LBS. (264 IN./LBS.)
 RECOMMENDED MAXIMUM TORQUE: 10 FT./LBS. (120 IN./LBS.)

VTE Incorporated
 5437 Robinson Road, P.O. Box 790
 Pellston, Michigan 49769
 Telephone: 1-800-527-9256, 231-539-8000
 FAX: 231-539-0914

REF: ***	DATE: 24JAN09	DRN BY: BRH	WEIGHT: ***
TITLE: 5/16" POWER DISTRIBUTION STUD			SCALE:
MATERIAL:		PART NO.	
COLOR:	DRG CLASS: ***	KQ77131 N02	