

THE INFORMATION CONTAINED IN THIS DRAWING IS THE SOLE PROPERTY OF VTE INCORPORATED. ANY REPRODUCTION IN PART OR WHOLE WITHOUT THE WRITTEN PERMISSION OF VTE INCORPORATED IS PROHIBITED.

LTR.	REVISIONS	DATE
*	*****	*****

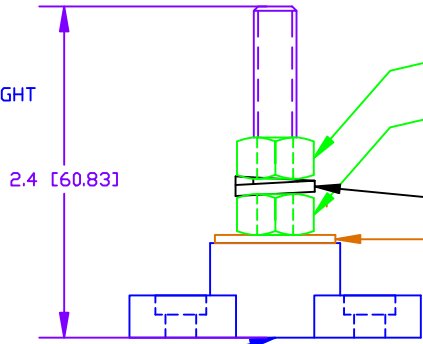
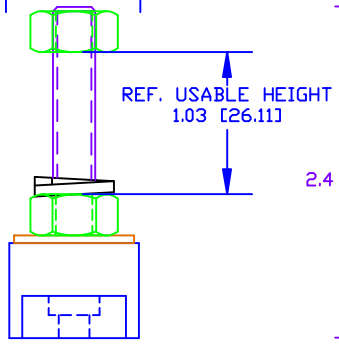
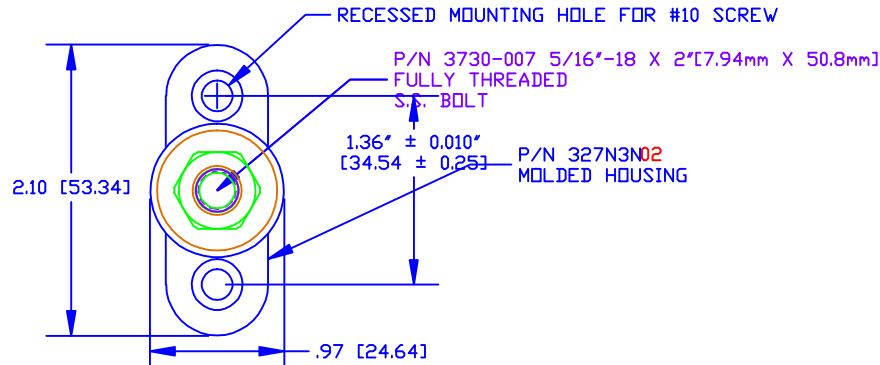

OPTIONAL CONSTRUCTION NOTE:
COLOR OF BOLT CAVITY PLUG ON BOTTOM OF ASSEMBLY MAY VARY

- P/N 3843-001 5/16"-18 STAINLESS STEEL HEAVY JAM NUT
- P/N 3843-000 5/16"-18 TIN PLATED BRASS JAM NUT BOTTOM NUT FACTORY ASSEMBLED TO 12 FT./LBS. (144 IN./LBS.)
- P/N 3642-000 5/16" STAINLESS STEEL SPRING WASHER
- P/N 3645-000 5/16" STAINLESS STEEL FLAT WASHER

TOLERANCE UNLESS OTHERWISE SPECIFIED: ±0.030"/±0.8mm
RADIAL DIAMETERS TO BE MEASURED OVER MANDRELS,
RING GAGES OR PIN GAGES OF SUITABLE SIZE

BASE MATERIAL: GLASS-REINFORCED NYLON
 BASE MATERIAL U.L. RATING: 94 HB
 DIELECTRIC STRENGTH: 630 VOLTS/MIL PER ASTM D149
 CURRENT RATING: 250 AMPS
 TEMP. RISE AT LOAD: 52 DEG. F.
 MAXIMUM RECOMMENDED TORQUE: 10 FT./LBS. (120 IN./LBS.)

DO NOT SCALE

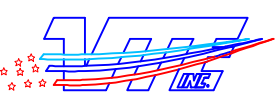

VTE Incorporated
 5437 Robinson Road, P.O. Box 790
 Pellston, Michigan 49769
 Telephone: 1-800-527-9256, 231-539-8000
 FAX: 231-539-0914

REF: *****	DATE: 05DEC06	DRN BY: BRH	WEIGHT: *****
TITLE: 5/16"X2" SMALL JUNCTION STUD			SCALE:
MATERIAL:		PART NO.	
COLOR: RED	DRG CLASS: *****	0077031N02 -X	