

THE INFORMATION CONTAINED IN THIS DRAWING IS THE SOLE PROPERTY OF VTE INCORPORATED. ANY REPRODUCTION IN PART OR WHOLE WITHOUT THE WRITTEN PERMISSION OF VTE INCORPORATED IS PROHIBITED.

LTR.	REVISIONS	DATE
*	*****	*****

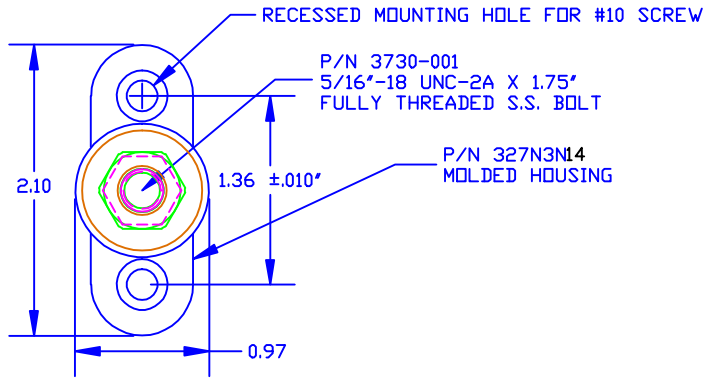

OPTIONAL CONSTRUCTION NOTE:
COLOR OF BOLT CAVITY PLUG
ON BOTTOM OF ASSEMBLY MAY VARY

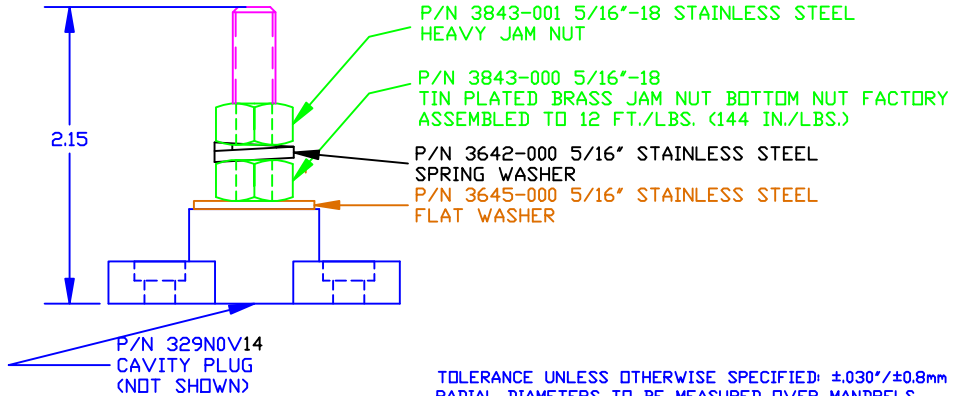
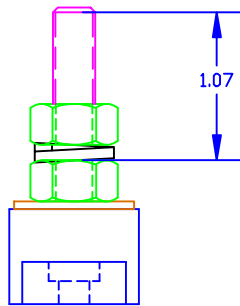

TOLERANCE UNLESS OTHERWISE SPECIFIED: ±.030"/±0.8mm
RADIAL DIAMETERS TO BE MEASURED OVER MANDRELS,
RING GAGES OR PIN GAGES OF SUITABLE SIZE

BASE MATERIAL: GLASS-REINFORCED NYLON
 BASE MATERIAL U.L. RATING: 94 HB
 DIELECTRIC STRENGTH: 630 VOLTS/MIL PER ASTM D149
 CURRENT RATING: 250 AMPS
 TEMP. RISE AT LOAD: 46 DEG. F.
 MAXIMUM RECOMMENDED TORQUE: 10 FT./LBS. (120 IN./LBS.)

(A)
(B)

DO NOT
SCALE

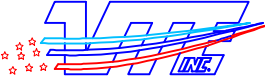
		VTE Incorporated 5437 Robinson Road, P.O. Box 790 Pellston, Michigan 49769 Telephone: 1-800-527-9256, 231-539-8000 FAX: 231-539-0914	
		REF: *****	DATE: 23JAN12
TITLE: 5/16" X 1.75" SMALL JUNCTION STUD			SCALE:
MATERIAL: BLACK		PART NO. □S77031N14 -X	
COLOR: BLACK		DRG CLASS *****	