

THE INFORMATION CONTAINED IN THIS DRAWING IS THE SOLE PROPERTY OF VTE INCORPORATED. ANY REPRODUCTION IN PART OR WHOLE WITHOUT THE WRITTEN PERMISSION OF VTE INCORPORATED IS PROHIBITED. VTE MAKES NO WARRANTY, EXPRESSED OR IMPLIED, AS TO THE SUITABILITY OF A PRODUCT FOR ANY INTENDED USE. THE CUSTOMER SHALL BEAR THE SOLE RESPONSIBILITY OF DETERMINING THE SUITABILITY OF ANY VTE PRODUCT FOR ITS END USE.

LTR.	REVISIONS	DATE	INT.
A	3844-012 WAS 3844-000	11-01-16	JMM
B	REVISED TORQUE FROM 144 IN./LBS.	05-11-17	RAS
C	ADDED LOCKTITE FOR CONTACT NUT ASSEMBLY	05-11-17	RAS
D	3844-B00 WAS 3844-000	6-02-17	JMM
E	UPDATED AND ADDED DIMENSIONS FOR MOUNTING	7-31-17	RAS
F	UPDATED ELECTRICAL VALUES	10-25-18	RAS
G	UPDATED TORQUE VALUE	7-01-20	EJE
H	UPDATED PART # FROM 3742-000	8-18-21	RAS
I	UPDATED PART # FROM 327D4	8-23-21	RAS
J	UPDATED TORQUE VALUE FROM 160 IN/LBS	8-26-21	RAS
K	UPDATED ELECTRICAL VALUES	10-18-22	RAS

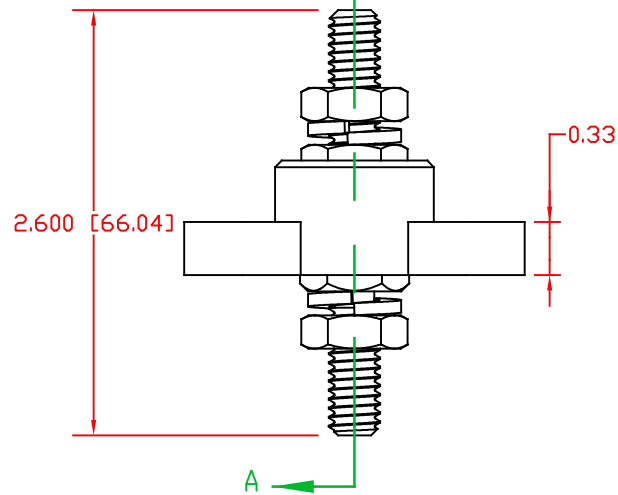
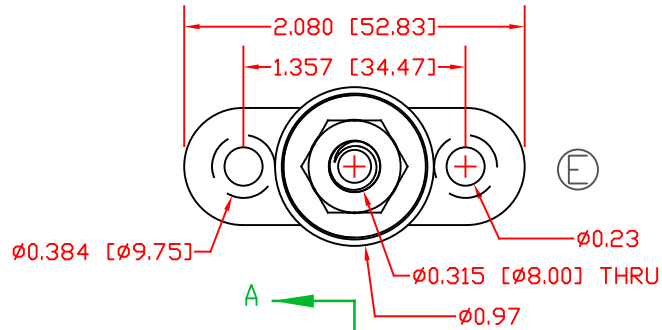

3742-018 NICKEL PLATED BRASS THREADED BOTH ENDS (H)

3844-B00 3/8-16 HEAVY HEX JAM NUT TIN PLATED BRASS FACTORY ASSEMBLED TO 150 IN./LBS. BLUE DOT TECHNOLOGY (DO NOT REMOVE) (J) (D)

3646-000 STAINLESS STEEL FLAT WASHER

327D7N02 NYLON HOUSING (I)

3638-000 STAINLESS STEEL SPRING WASHER, 2 PCS

SECTION A-A

3844-012 3/8-16 HEAVY HEX JAM NUT STAINLESS STEEL, 2 PCS. MAXIMUM RECOMMENDED FASTENER TORQUE: 136 IN./LBS. (A) (B) (G)

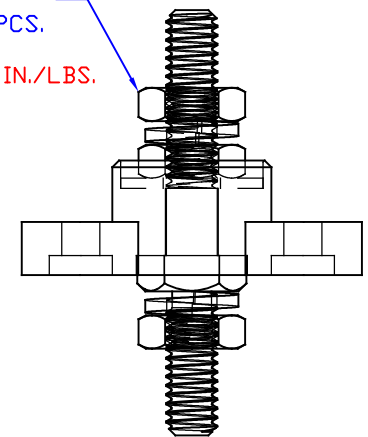

SCALE FACTOR: NONE
 ALL DIMENSIONS GIVEN AS: in [mm]
 TOLERANCES UNLESS OTHERWISE SPECIFIED:
 MOLDED PARTS: ±.030" [±0.8mm]
 HARDWARE ITEMS: ±.010" [±0.25mm]

INCLUDES P-16808110001 BLUE DOT MULTI LABEL, 1 PER CONTAINER

MATERIAL PART NO:
 MATERIAL:
 VENDOR PART NO:
 SPECIFIC GRAVITY:
 MELTING TEMP:
 U.L. RATING:

711210502
 GLASS FILLED NYLON
 NYLON N2015 HL NAT
 1.23
 515 F [268 C]
 UL 94 HB

CURRENT CARRYING CAPACITY: (375 AMP @ 12VDC)

		VTE Incorporated 5437 Robinson Road, P.O. Box 790 Pellston, Michigan 49769 Telephone: 1-800-527-9256, 231-539-8000 FAX: 231-539-0914	
		REF: CUSTOMER DIMS	DATE: 8-26-21
TITLE: JUNCTION BLOCK, STUD TYPE, PASS-THRU			SCALE: NONE
MATERIAL: GLASS FILLED NYLON		PART NO.	
COLOR: RED	DRG CLASS: REV K	77237N02	