

THE INFORMATION CONTAINED IN THIS DRAWING IS THE SOLE PROPERTY OF VTE INCORPORATED. ANY REPRODUCTION IN PART OR WHOLE WITHOUT THE WRITTEN PERMISSION OF VTE INCORPORATED IS PROHIBITED. VTE MAKES NO WARRANTY, EXPRESSED OR IMPLIED, AS TO THE SUITABILITY OF A PRODUCT FOR ANY INTENDED USE. THE CUSTOMER SHALL BEAR THE SOLE RESPONSIBILITY OF DETERMINING THE SUITABILITY OF ANY VTE PRODUCT FOR ITS END USE.

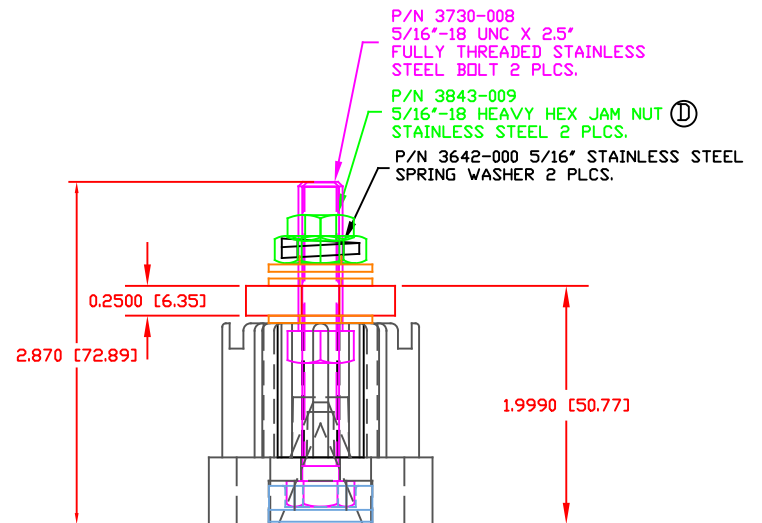
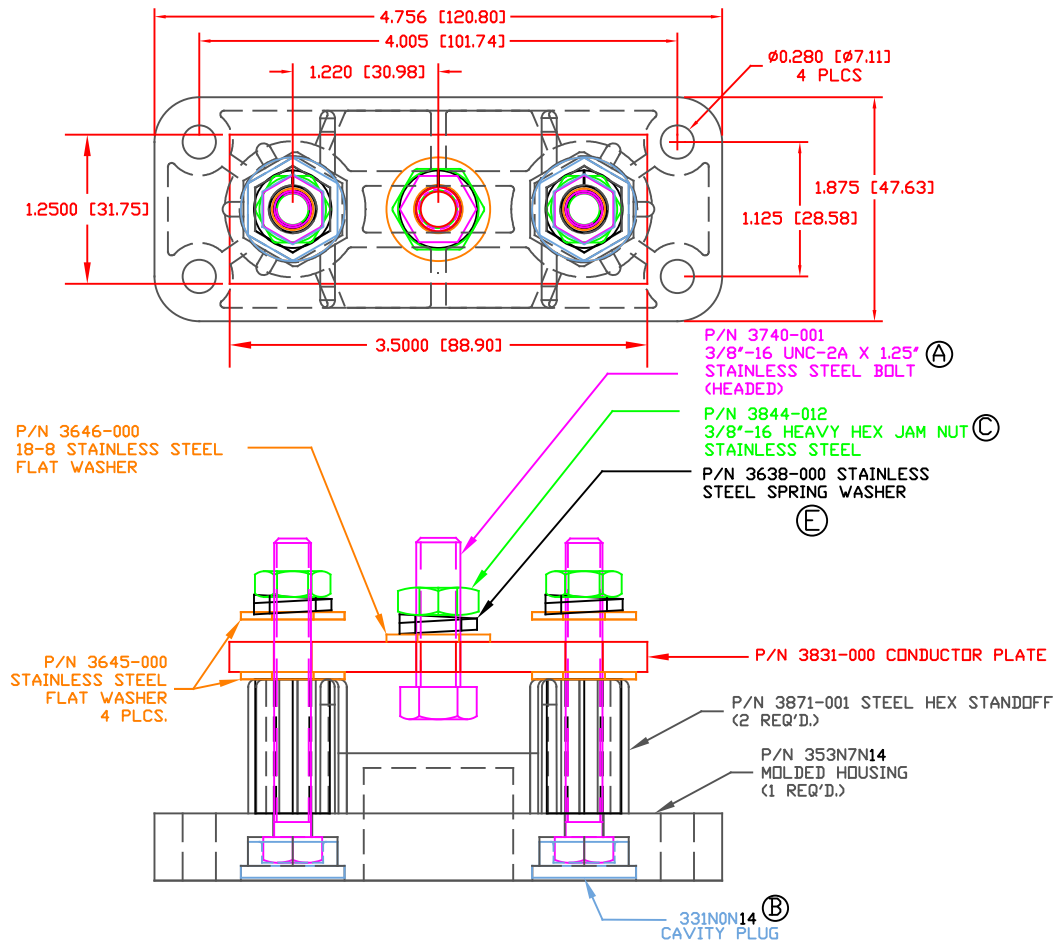

SCALE FACTOR : NONE
 ALL DIMENSIONS GIVEN AS: in [mm]
 TOLERANCES UNLESS OTHERWISE SPECIFIED :
 MOLDED PARTS: ±.030" [±0.8mm]
 HARDWARE ITEMS: ±.010" [±0.25mm]

LTR.	REVISIONS	DATE	INT
A	3740-001 WAS 3740-006	04-14-08	BRH
B	PN 331NOV** CHANGED TO PN 331NON**	08-05-16	MDL
C	3844-012 WAS 3844-003	11-01-16	JMM
D	REPLACED P/N 3843-001 WITH P/N 3843-009	01-16-17	RAS
E	REMOVED BOTTOM LOCKWASHER	04-02-24	RAS

MATERIAL PART NO:
 MATERIAL:
 VENDOR PART NO:
 SPECIFIC GRAVITY:
 MELTING TEMP:
 U.L. RATING:

111210514UL
 GLASS FILLED NYLON
 HYLON N2015 HL BK
 1.23
 515 F [268 C]
 UL 94 HB

MAXIMUM AMPERAGE:
 RECOMMENDED MAXIMUM FASTENER TORQUE:

700 AMPS @12VDC
 3/8"-16 180 IN./LBS.
 5/16"-18 120 IN./LBS.



VTE Incorporated
 5437 Robinson Road, P.O. Box 790
 Pellston, Michigan 49769
 Telephone: 1-800-527-9256, 231-539-8000
 FAX: 231-539-0914

REF:	DATE:	DRN BY:	BRH	WEIGHT:
CUSTOMER DIMS	3-26-08	CHK'D BY:	BRH	0.927 lbs [420.48 g]
TITLE: BUS BAR, HI-AMP 3 POINT				SCALE:
MATERIAL: GLASS FILLED NYLON			PART NO.	
COLOR: BLACK			7753N7N14	
DRG CLASS		REV E		